



**PEFLEX  
REQNET**



# PRODUCT CATALOG

*The most popular ventilation system in Poland*



# PEFLEX REQNET

## COMPANY HISTORY

**PEFLEX and REQNET** are closely cooperating brands offering a complete mechanical ventilation system with heat recovery, manufactured in Poland, for single-family houses. Our product range includes all components of the recuperation system such as: **ducts, expansion and distribution boxes, diffusers, air intakes and outlets, accessories, and intelligent recuperators.**

**PEFLEX** was the first company in Poland in 2009 to introduce double-walled, corrugated **PE-HD flex ducts** of its own Polish production in the characteristic green colour, which have become **the most popular ducts used in mechanical ventilation.** The name „peflex” has become a common name for ducts of this type in ventilation. A lot has changed since then. Our product range has expanded considerably, giving customers a range of options while at the same time ensuring the highest level of hygienic installation and user comfort and, most importantly, fresh and clean air in their homes.

**REQNET** recuperators are well-thought-out devices created for mechanical ventilation systems in single-family houses. While designing them, we have put particular emphasis on comfort and ease of use, while also ensuring **optimal ventilation for the health of household members.**

## Mechanical ventilation PEFLEX

Modern mechanical ventilation, through regular air exchange throughout the building, ensures a **high level of comfort** in living spaces. An intelligent and efficient ventilation system guarantees fresh, clean and healthy air in single-family houses.

Mechanical ventilation, or recuperation, also has a huge impact on the energy efficiency of buildings. In modern, energy-efficient construction, an important issue is to **reduce energy losses**, and the recuperation system allows you to reduce the need for heat by up to **30%** in the entire heat balance. The **heat exchanger** used in the recuperator ensures energy and moisture recovery, which is important especially in winter.

Efficient recuperation **ensures an optimal level of carbon dioxide** in rooms by **supplying fresh, filtered air and removing pollutants, viruses, and dust from the indoor environment.**

### Advantages of mechanical ventilation

- Fresh and clean air all year round
- Optimal levels of carbon dioxide and humidity in the home
- Compliance with the technical conditions of the building in accordance with the WT 2021 (Technical Conditions for Construction 2021)
- Air filtration of incoming air, including allergens and smog
- Removal of used air from the house together with contaminants such as dust, viruses
- Energy recovery - supply air is heated by warm exhaust air
- Lower heating costs - savings of up to 50%
- No need to open windows and associated heat losses
- Full control over the amount of exchanged air
- No need to build expensive and unsightly ventilation chimneys

**Plan fresh and clean air in your home!**

# Key features of the PEFLEX system

## Flexibility and ease of configuration

The components of the system allow for any configuration of the system to best suit the building. **The components are compatible with each other** and designed to form a single, sealed ventilation system. **Different duct diameters** and different types and variants of **plenum and distribution boxes** can be used in a single system for the most efficient distribution of the installation.

## Easy and quick installation

The connection system used, based on a **CLIK connector**, allows for quick installation of ventilation ducts with system components such as the distribution box, plenum box, or coupler. The CLIK connector enables **easy assembly and disassembly of the ducts, and with the built-in gasket inside**, there is no need for additional sealing. **A dedicated duct cutter** speeds up the entire installation process.



## Durability

Ventilation system components are made of **durable materials** such as PE-HD plastic, polypropylene and stainless steel.

Ventilation ducts have a **resistance** to external pressure of over **800 N**, which allows for safe installation in the **insulation layer of the floor**. The whole system can function smoothly for years of use.

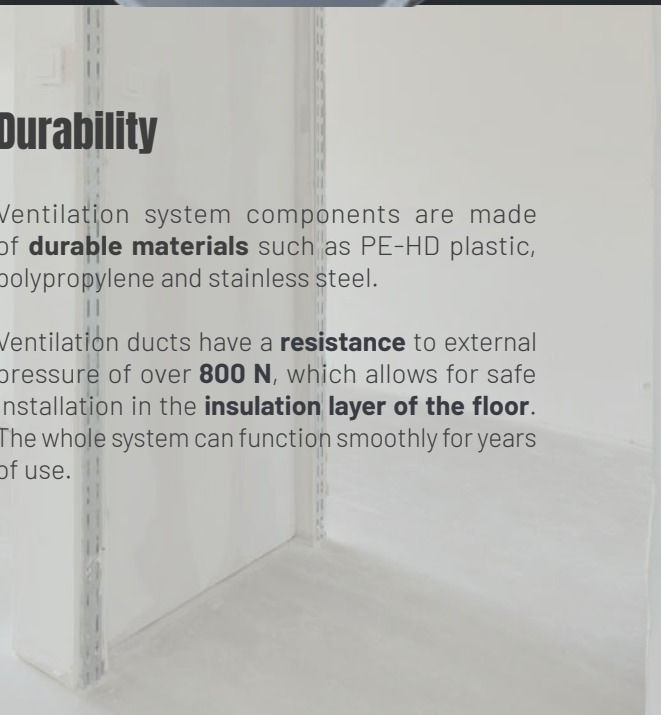

## Biological protection

The materials and additives used provide **biological protection** for the ventilation system, ensuring the safety and health of users. The Spectra 1000 ventilation duct provides the **highest biological protection** of almost 100%. The inner layer of the duct has **antibacterial, antifungal and antistatic properties**, which additionally reduce the settlement of dirt - dust.

All PEFLEX ducts are certified hygienically by the National Institute of Public Health - National Institute of Hygiene.



## Tightness

The **CLICK connector** is a system solution used in all elements requiring connection with **PEFLEX** duct. The connector has **a built-in inner gasket** that guarantees a tight connection and a dedicated duct cutter ensures a proper edge of the duct that fits snugly against the gasket. PEFLEX ventilation ducts combined with our plenum and distribution boxes provide a high degree of **airtightness** for the entire system (class „C” according to EN 12237).

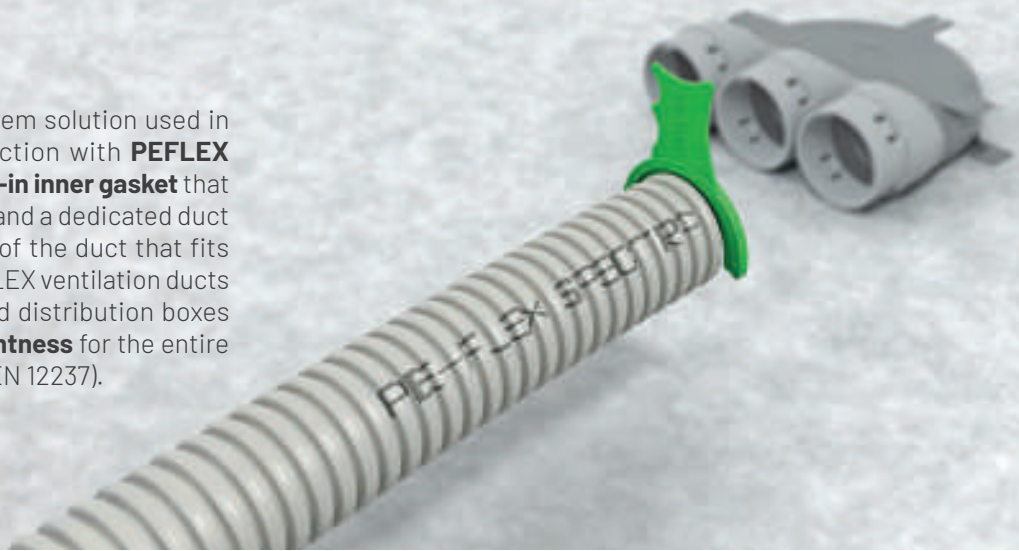

## Noise

A correctly designed system based on **PEFLEX** mechanical ventilation, especially the double-walled design of the ventilation ducts with the correspondingly profiled inner wall and the closed air cavities, ensures low noise levels in the entire system during operation.



# Plan fresh and clean air at home with our products!

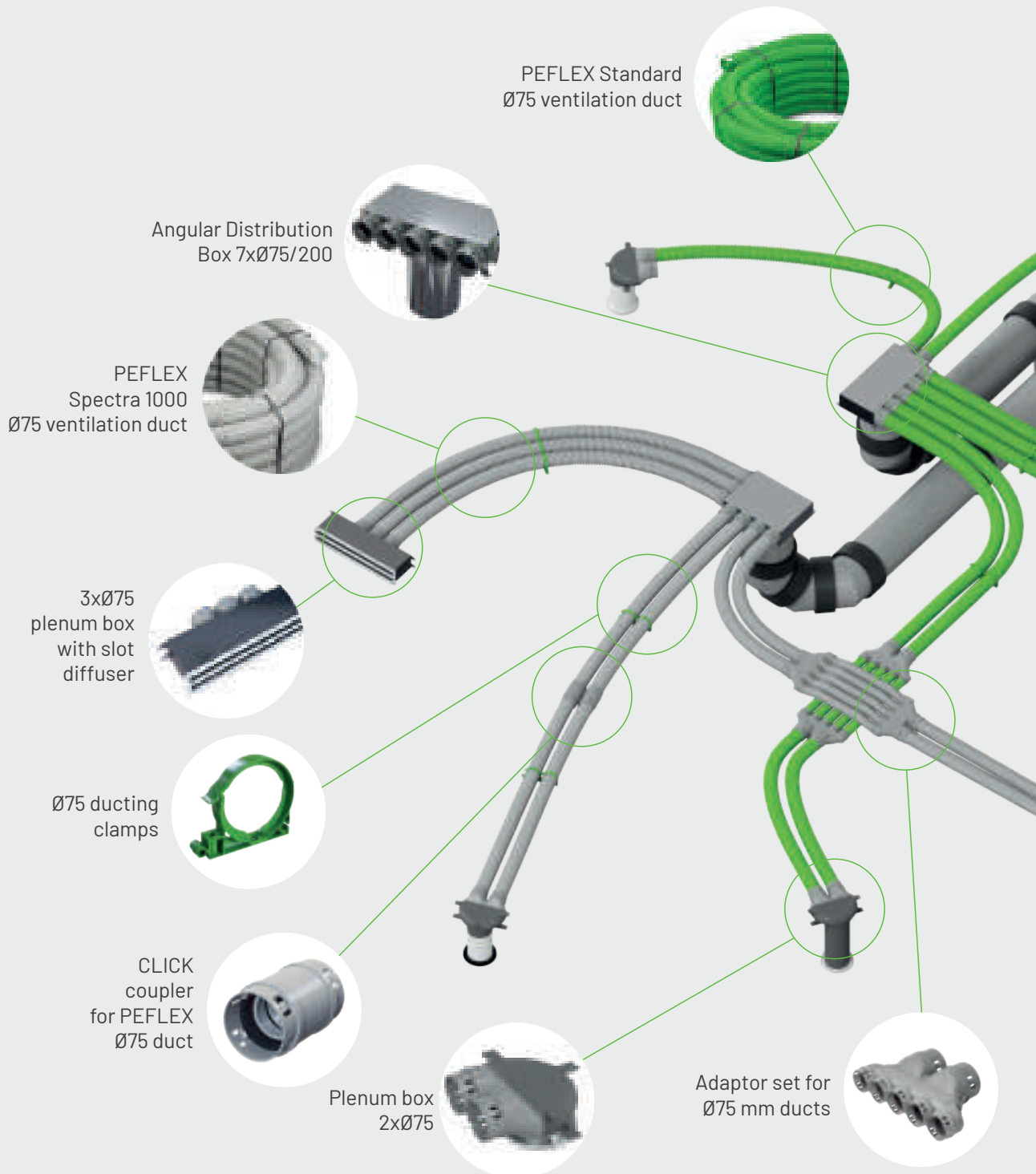

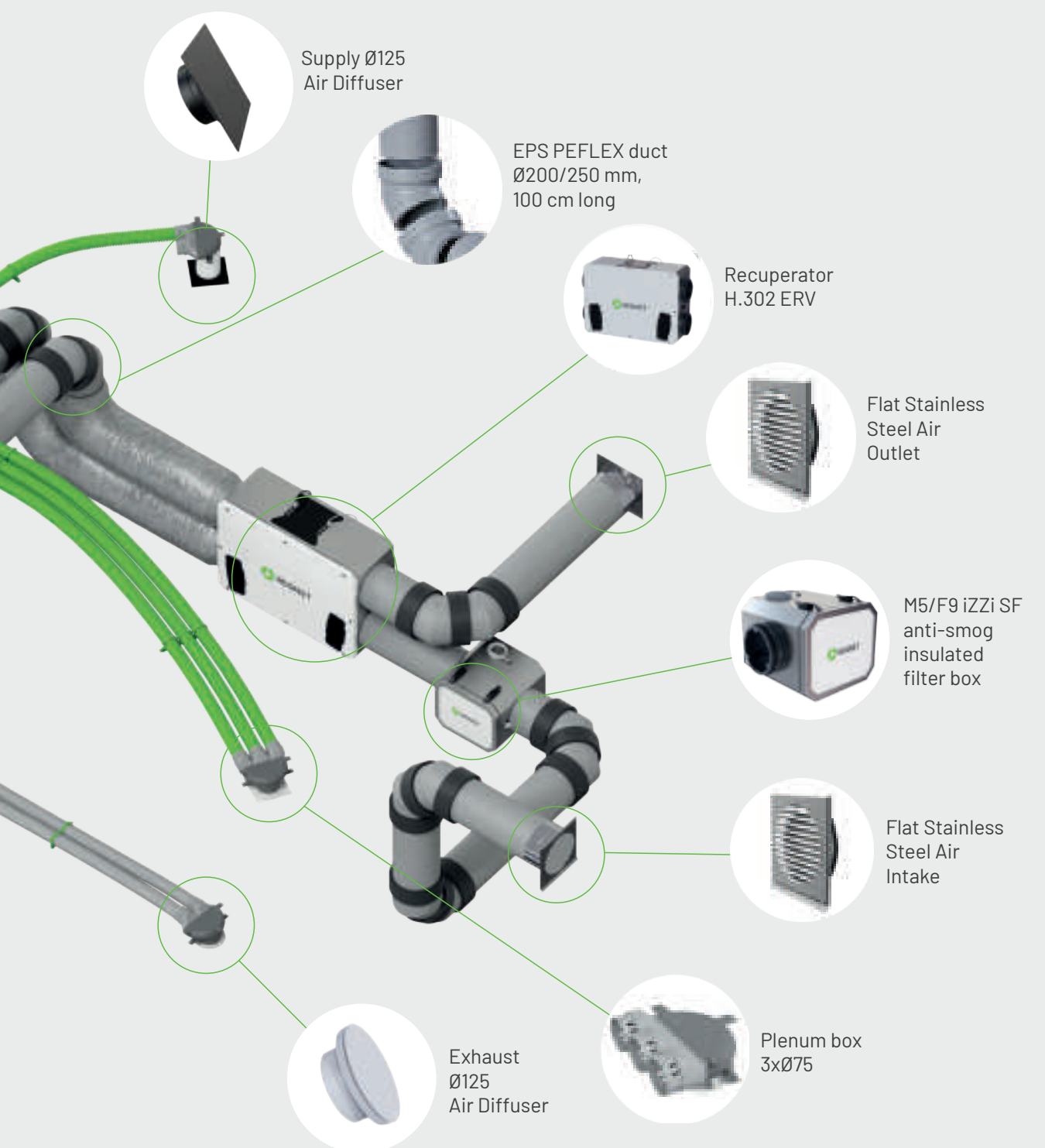

Supply Ø125  
Air Diffuser

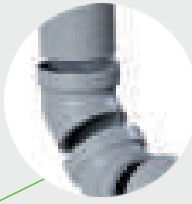

EPS PEFLEX duct  
Ø200/250 mm,  
100 cm long



Recuperator  
H.302 ERV

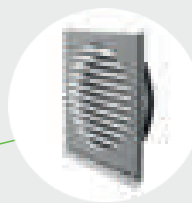

Flat Stainless  
Steel Air  
Outlet



M5/F9 iZZi SF  
anti-smog  
insulated  
filter box

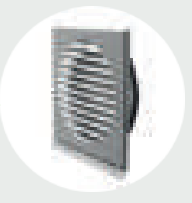

Flat Stainless  
Steel Air  
Intake



Exhaust  
Ø125  
Air Diffuser

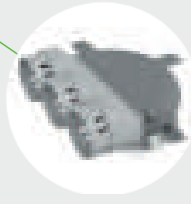

Plenum box  
3xØ75



# PEFLEX

The most popular ventilation  
system in Poland



# PEFLEX Standard ducts

Flexible corrugated **ventilation ducts**, with **antibacterial and antifungal** smooth inner layer, are made of high-quality PE-HD plastic with external dimensions of Ø50, Ø75 or Ø90.

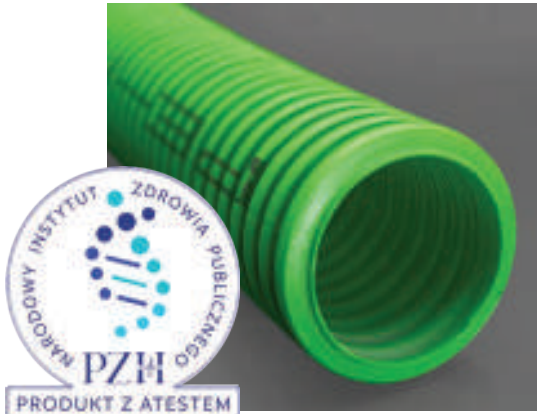

The product has a hygienic certificate, issued by National Institute of Public Health



## Key features

The internal layer contains bacteriostatic and fungistatic additives that inhibit the growth of microorganisms on the inner surface of the duct, with **biocidal effectiveness of up to 60%**.

The double-layer construction of the ducts ensures **high durability** and allows the ducts to be embedded in structural concrete or placed within the ceiling insulation layer.

**The high flexibility of the ducts** significantly simplifies installation by allowing easy shaping, bending, and routing of the ducts without the need for additional fittings.

The ducts are fully **odorless**, so they do not emit any odor.

The inner layer has **antistatic** properties, which reduces the settling and accumulation of dust in the ducts, and additionally the smooth surface facilitates cleaning.



High impact strength



Ag, Cu, +



Antifungal product



Antibacterial product



Antistatic

**The ducts have a fire reaction class of D-s2,d2.**

They are certified with a hygiene certificate, issued by the National Institute of Public Health.

Type of duct:	PEFLEX 50		PEFLEX 75		PEFLEX 90
Outer diameter [mm]	Ø50		Ø75		Ø90
Inner diameter [mm]	Ø40		Ø60		Ø75
Coil length [m]	100	20	50	15	40
Flow capacity [m <sup>3</sup> /h] at 3 m/s	12		30		45

# PEFLEX SPECTRA 1000 ducts

**Flexible ventilation ducts** with a corrugated structure, and **excellent antibacterial and antifungal** properties, are made from **high-quality PE-HD material** with external dimensions of Ø50, Ø75, or Ø90 mm.

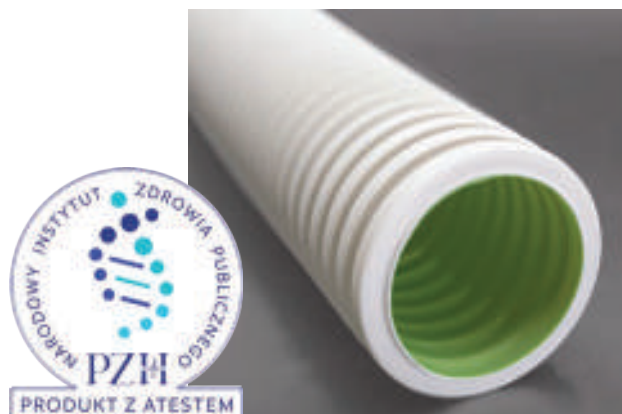

The product has a hygienic certificate, issued by National Institute of Public Health



## Key features

The antibacterial and antifungal inner layer, certified with nearly **100% biocidal efficiency**, protects the ducts from the colonization of unwanted and harmful microorganisms.

The double-layer construction of the ducts ensures **high durability** and allows the ducts to be embedded in structural concrete or placed within the ceiling insulation layer.

**The high flexibility** of the ducts significantly simplifies installation by allowing easy shaping, bending, and routing of the ducts without the need for additional fittings.

The inner layer has **antistatic** properties, which reduces the settling and accumulation of dust in the ducts, and additionally the smooth surface facilitates cleaning.

The ducts are fully **odorless**, so they do not emit any odor.



High impact strength



Ag, Cu, +



Antifungal product



Antibacterial product



Antistatic



Spectra

**The ducts have a fire reaction class of D-s2,d2.**

They are certified with a hygiene certificate, issued by the National Institute of Public Health.

Type of duct:	PEFLEX 50		PEFLEX 75		PEFLEX 90
Outer diameter [mm]	Ø50		Ø75		Ø90
Inner diameter [mm]	Ø40		Ø60		Ø75
Coil length [m]	100	20	50	15	40
Flow capacity [m <sup>3</sup> /h] at 3 m/s	12		30		45

# PEFLEX Premium insulated ventilation ducts

High-quality PEFLEX Premium flexible insulated ventilation ducts for mechanical ventilation are primarily used **to connect the recuperator with distribution boxes.**



The product has a hygienic certificate, issued by National Institute of Public Health



Antibacterial product



## Key features

The ducts are available in two variants: with microperforations and with **microperforations and an internal antibacterial layer.**

The microperforations in the inner layer ensure noise dampening, which enhances the comfort of using the ventilation system.

The inner antibacterial green layer inhibits bacterial growth, ensuring hygienically clean air.

A clear vapour barrier foil sleeve between the inner jacket and the insulation fleece protects the polyester insulation fleece from water penetration and the duct interior from microscopic fleece particles.

## The main advantages of non-woven polyester insulation:

- It does not irritate the skin or produce dust during installation,
- there is no risk of wool particles entering the ductwork,
- it is more resistant to moisture and water,
- it has a thermal conductivity coefficient ( $\lambda$ ) comparable to that of mineral wool.

They are certified with a hygiene certificate, issued by the National Institute of Public Health.

Isolation thickness	25 mm		50 mm	
Thermal insulation	polyester fibres (dust-free)			
Max. pressure	+2500 Pa			
Max. air velocity	25 m/s			
Available diameters (internal) of the duct	127 mm	165 mm	203 mm	254 mm
Length after stretching	10 m			
Temperature resistance	from -30°C to +140°C			
Country of origin	Poland			

## PEFLEX distribution boxes

**PEFLEX distribution boxes** are **customized** and manufactured to individual order - they can have any dimensions and spigot arrangement. Using the **BOXMAKER** software, you can design a custom box with a quick turnaround time. Optimally selected distribution boxes will allow you to install the ventilation system and connect the recuperator **more quickly, easily, and effectively**.

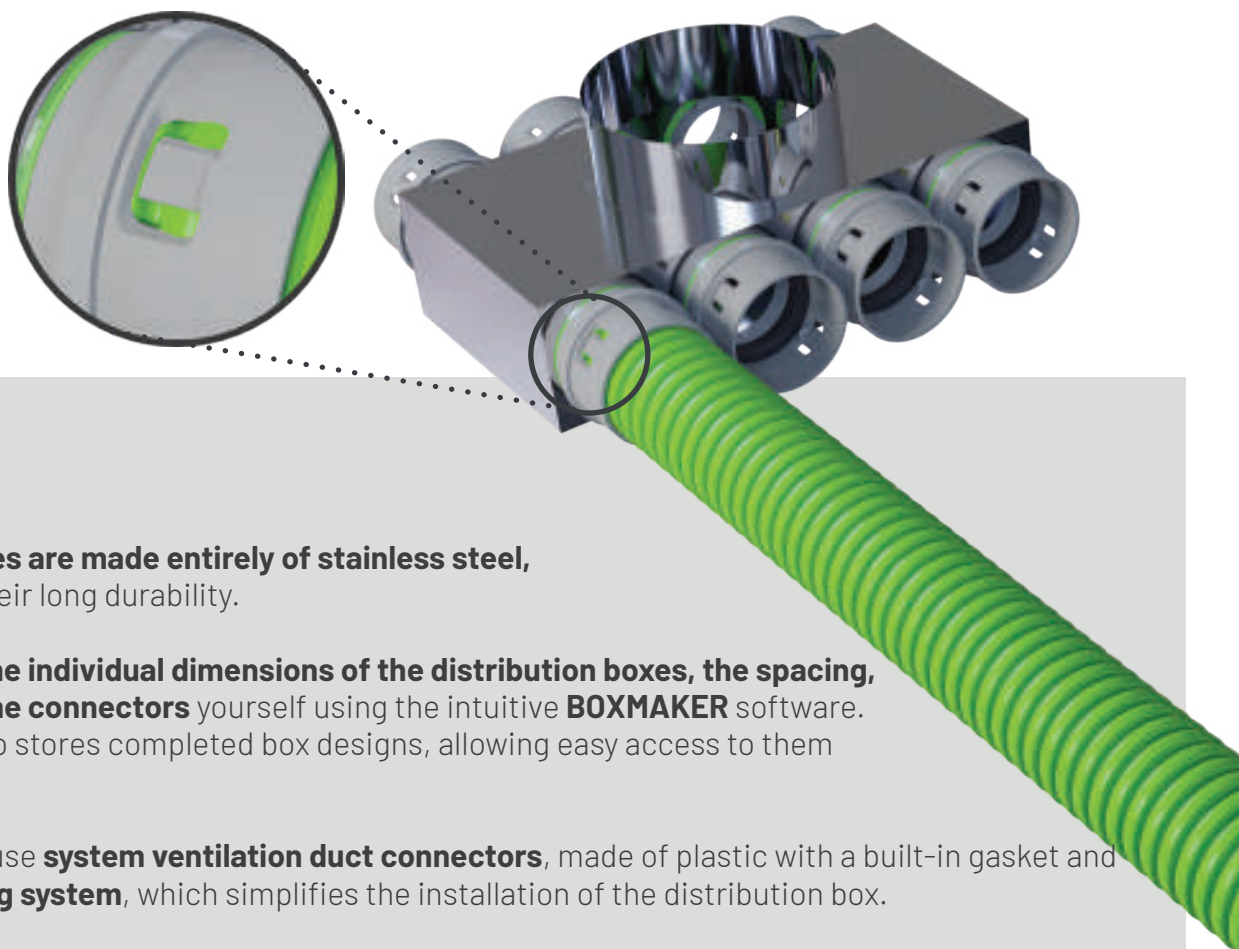

### Key features

**Distribution boxes are made entirely of stainless steel**, which ensures their long durability.

You can design **the individual dimensions of the distribution boxes, the spacing, and the size of the connectors** yourself using the intuitive **BOXMAKER** software. This program also stores completed box designs, allowing easy access to them in the future.

In the boxes, we use **system ventilation duct connectors**, made of plastic with a built-in gasket and **a CLICK mounting system**, which simplifies the installation of the distribution box.

**PEFLEX** ventilation ducts, when connected with plenum and distribution boxes, ensure **high-class airtightness for the entire system**.

The **BOXMAKER** program also allows you to plan **mounting brackets** on any surface of the box.

The refined production process for distribution boxes enables the completion of projects within **24 hours**.

Box dimension	Number and size of spigots	Main spigots	Type of box (angle, pass-through)	Mounting brackets
Individually specified	to your choice	to your choice type and size	to your choice	to your choice

## PEFLEX Plenum boxes

**PEFLEX PLENUM boxes** are used to connect flexible ducts to diffusers. They are made of durable plastic, have connectors with gaskets, are assembled using the **CLICK system**, and are available in various connection versions.



### Key features

The boxes are made of **durable plastic**, which allows them to be placed in the insulation layer of the ceiling.

**A wide range of box versions** makes it possible to mount the mechanical ventilation system both under the ceiling and directly on the ceiling.

The connectors in the boxes are made of plastic and have **pre-installed gaskets** and a **CLICK assembly system**, which greatly speeds up installation and guarantees a tight installation.

PEFLEX ventilation ducts, when connected with plenum and distribution boxes, **ensure high-class airtightness of the entire system.**

**Diffusers** with a diameter of  $\text{\O}125$  mm can be **directly connected** by means of an diffuser frame inserted into the plenum box in the socket version, or by means of a plenum box extension in the nipple version.

Unused connectors in the box **can be closed with dedicated plugs**, ensuring the tightness of the installation.

The boxes have convenient **mounting brackets.**

Number of sockets in plenum boxes

2x $\text{\O}75$

3x $\text{\O}75$

2x $\text{\O}90$

5x $\text{\O}50$

## All plastic boxes are offered in three versions:

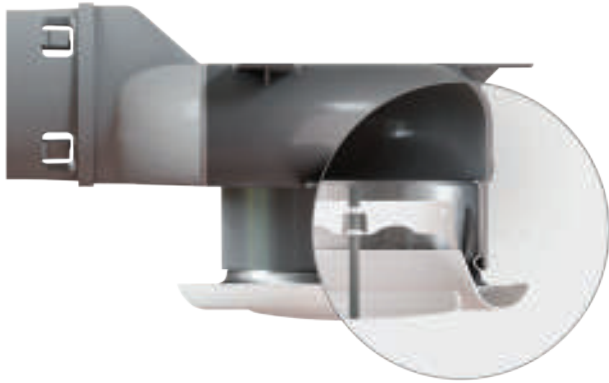

- **With a short socket spigot**

A 5 cm long and with Ø125 mm internal diameter spigot for direct connection of Ø125 mm diffuser frame.



- **With a short nipple spigot**

A 5 cm long and with Ø123 mm diameter spigot enabling extension of the box stub with our extensions, flexible duct or any duct with diameter Ø125.

- **With a long socket spigot New!**

A 30 cm long and with Ø125 mm internal diameter spigot for direct connection of Ø125 mm diffuser frame.



**Available in the second  
half of 2025**

A built-in **30 cm** long socket spigot for Ø125 diffuser.

Innovative technology providing **constant internal (Ø125 mm) and external (Ø129 mm) diameter along its entire length.**

Markers with a scale that facilitate cutting the spigot to the required length.

**Plastic plenum boxes 2xØ75, 3xØ75 and 2xØ90 are additionally available in two variants:**

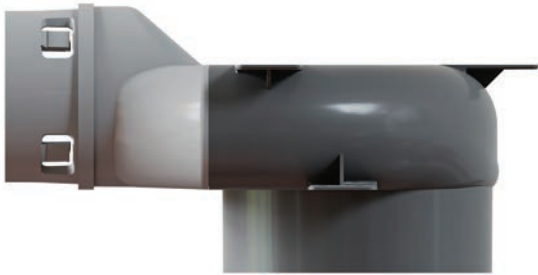

- **Floor mounting - installation on the floor**

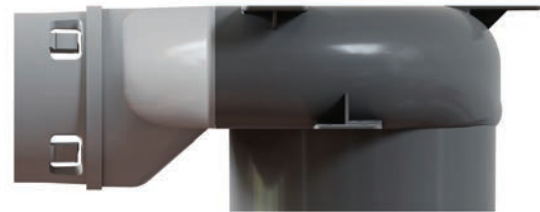

- **Ceiling mounting - installation under the ceiling**

## Plastic plugs

Plugs are made of PP plastic used to plug unused spigots in plenum boxes of various diameters. The plugs are matched to the diameter of the sockets and the diameter of the spigots for diffusers.



### Key features

Plugs with diameters **Ø 50mm, Ø 75mm and Ø90mm** are used to plug unused CLICK connectors in plenum and distribution boxes.

Plugs with diameters of **Ø100mm, Ø125mm, Ø160mm, Ø200mm, and Ø250mm** are used in plenum boxes to secure connections for air diffusers or in distribution boxes to secure connections for ventilation ducts.

**Simple push-fit assembly.**

## PEFLEX INOX plenum boxes

The stainless steel plenum boxes feature system connectors with built-in gaskets and **CLICK mounting**, as well as spigots designed for the direct installation of a diffuser frame. They are available in various connection configurations.

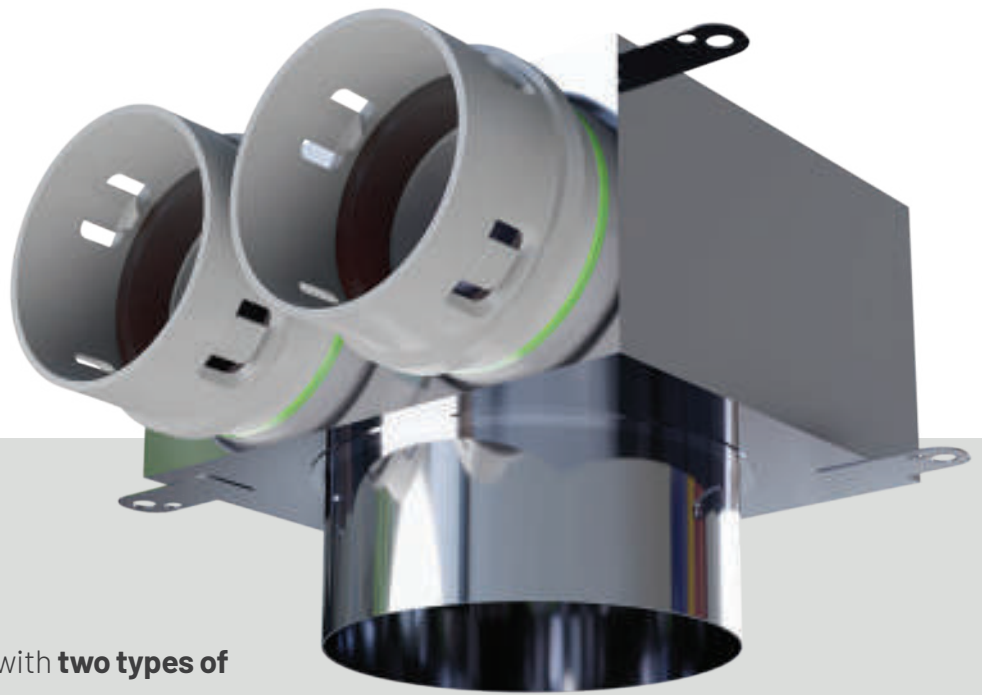

### Key features

The plenum boxes are available with **two types of spigots** for the diffuser:

- Designed for self-extension to the diffuser frame using a flexible duct, spiro duct, or plastic duct.
- Suitable for direct connection to the diffuser frame.

The boxes connectors are made of plastic and have a **factory-installed gaskets** and the **CLICK mounting system**, which significantly speeds up installation and guarantees a tight installation.

Spigots for diffusers are available in two variants: **socket and nipple**, and in three diameters. Additionally, it is possible to extend them.

Depending on the location of the diffuser, the boxes are available **in three variants: angular, pass-through and directional**.

The PEFLEX ducts connected to the plenum and distribution boxes provide a **high level of airtightness** throughout the system.

The boxes have a convenient mounting brackets.

Duct size	Ø50	Ø75	Ø90
Number of spigots	1-6	1-4	1-3



## PEFLEX INOX plenum boxes for slot diffusers

The stainless steel plenum boxes feature system connectors with built-in gaskets and a CLICK mounting system, and are specifically designed for slot diffusers. They are available in two versions: angular and pass-through.

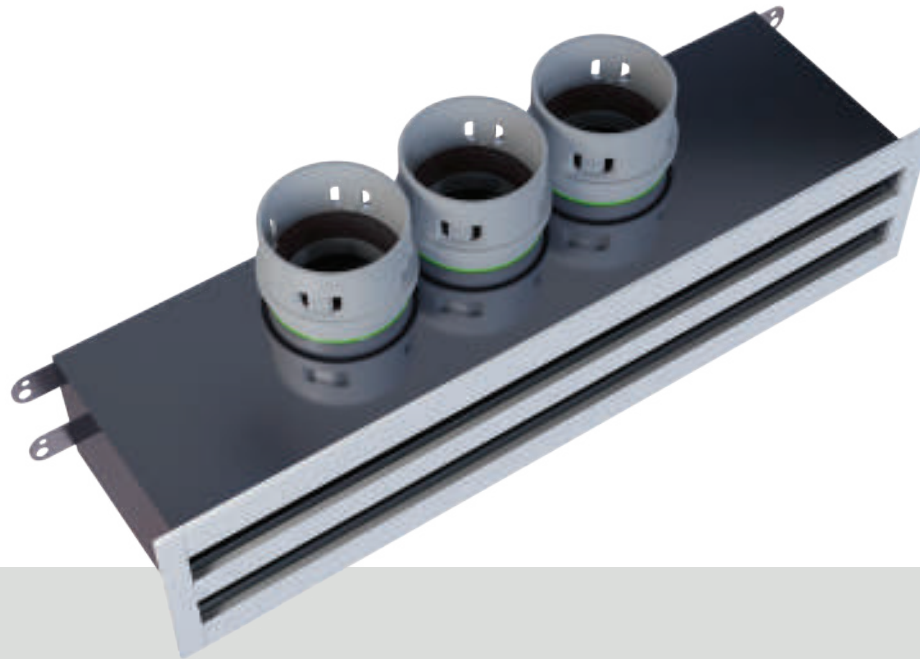

### Key features

The boxes are made entirely of **stainless steel**, which ensures its long-term durability.

The box connectors are made of durable plastic and have a factory-installed gaskets and the CLICK mounting system, which greatly speeds up installation and guarantees a tight installation.

Depending on the location of the slot diffuser, boxes are available **in two variants: angular and pass-through.**

**The boxes are designed to fit the PEFLEX slot diffuser.**

They have convenient mounting brackets.

Duct size	Ø50	Ø75	Ø90
Numer of spigots	7	3 or 4	2 or 3

## Slot diffusers

The linear slot diffusers are designed for air supply in ventilation **systems and are particularly suitable** for mounting on walls or vertical structures. Each slot is equipped with **independent blades** allowing for easy **change of direction** of the supplied air.



### Key features

They allow you **to conveniently direct and adjust the airflow** in different directions.

Original and minimalist design makes it suitable for **modern interiors**.

They are fitted to the PEFLEX slot plenum box, ensuring the tightness of the entire installation.

They provide **high airflow** performance of up to 120m<sup>3</sup>/h.

Overall length	Internal length	Material	Color
530 mm	495 mm	aluminum + plastic	RAL 9016 white glossy

# PEFLEX Adaptor set

A set of adapters(connectors)for collision-free crossing of ventilation ducts or crossing ducts with other installations, facilitating the installation of the ventilation system.



## Key features

**Complete sets** for making a duct crossing or crossing over installations, including: adapters, plugs and a ventilation duct.

The set makes it possible to **cross over PEFLEX flexible ventilation ducts**, without having to go over the polystyrene foam in the floor insulation.

It allows PEFLEX ventilation ducts **to cross over with other installations** without the need for rework.

The connectors in the adapters are made of durable plastic and have a **factory-installed gasket** and the **CLICK assembly system**, which significantly speeds up installation and guarantees a tight installation.

It is possible to use plugs and **create other configurations of adapters.**

Set 1		Set 2	Set 3		Set 4
2 pcs. of 5x50/2x75	2 pcs. of 5x50/2x75	1 pc. of 5x50/2x75	2 pcs. of 2x90/3x75	2 pcs. of 2x90/3x75	1 pc. of 2x90/3x75
5 meters of Ø50 mm duct	5 meters of SPECTRA Ø50 mm duct	plastic plugs	3 meters of Ø75 mm duct	3 meters of SPECTRA Ø75 mm duct	plastic plugs
plastic plugs	plastic plugs		plastic plugs	plastic plugs	

## PEFLEX CLICK couplers for ventilation ducts

The system **couplers for joining PEFLEX flexible ventilation ducts**, equipped with an **integrated gasket and a CLICK assembly system**, ensure a highly tight and durable connection between two duct sections. **They do not require additional seals or sealing with tape.**



### Key features

The couplers are available in **three sizes** according to the diameter of the PEFLEX ventilation ducts: Ø 50mm, Ø 75mm and Ø 90mm.

The couplers are **made of durable plastic**, which allows it to be placed in the insulation layer of the ceiling.

They have **a built-in factory gaskets** and **the CLICK assembly system**, which significantly speeds up installation and guarantees a tight installation.

The special design of the latches **prevents the ventilation ducts from dislodging.**

**They allow the use of ventilation duct ends.**

Outer diameter:

Ø50

Ø75

Ø90

## PEFLEX duct cutters

The PEFLEX **duct cutters** make it possible to **cut ventilation ducts** quickly and evenly. They considerably **improve the assembly of the ventilation system** and enable the duct to be **tightly connected** to the plenum and distribution boxes.

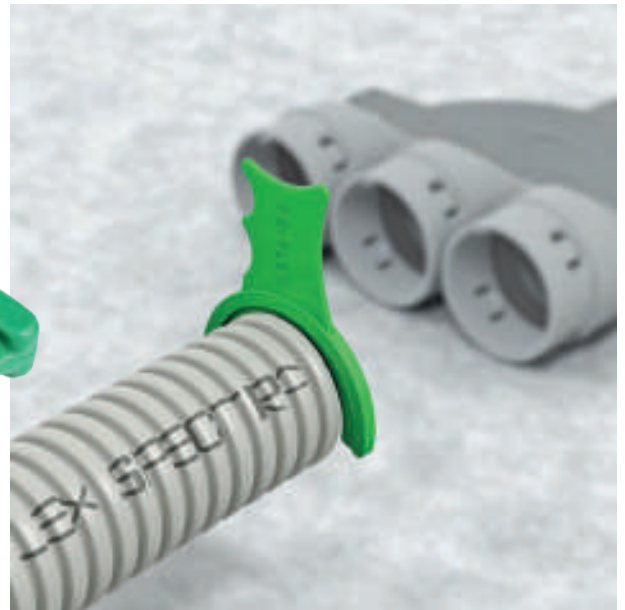

### Key features

Available in three sizes to **suit the diameter of the ventilation ducts**.

They guarantee **fast and precise cutting** of the PEFLEX ventilation duct, which consequently ensures tightness of the entire installation.

They facilitate assembly and significantly reduce the assembly time of the entire installation.

Available sizes:

Ø50

Ø75

Ø90

## PEFLEX Ducting Clamps

Specially developed holders for PEFLEX flexible ducts **enable quick installation** on ceilings and walls. The clamps can be connected in series with a tongue-and-groove connection, making it possible to install several ventilation ducts parallel to each other.

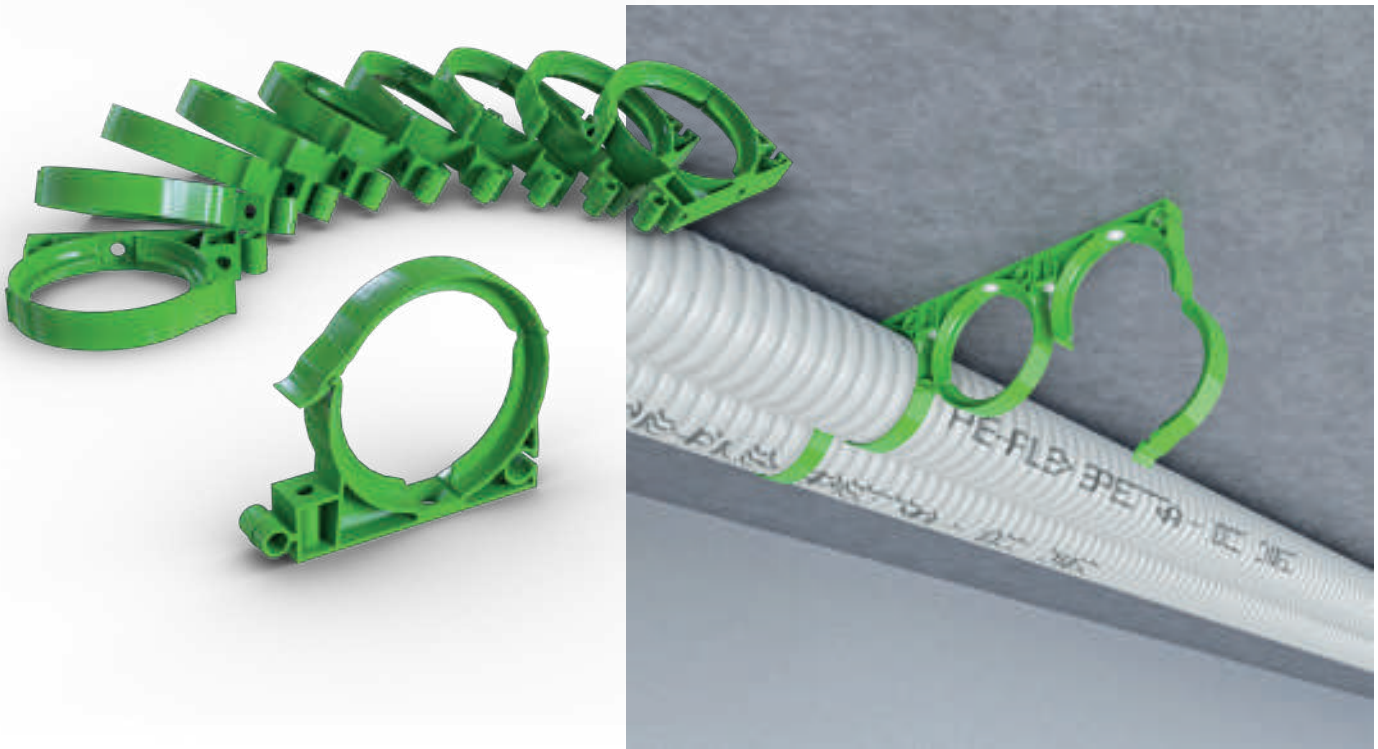

### Key features

Dedicated duct clamps **make it easy for one person** to install the PEFLEX ventilation system!

They allow for significant **time savings** during the installation of the entire system.

The mounting holes allow the clamps to be fixed to the ground with dowels or screws.

**They are suitable for flexible ducts** with an external diameter of Ø 75 mm.

Top closure facilitates the duct installation under the ceiling, and tongue and groove allows for quick connection of the brackets.

## PEFLEX Acoustic foam damper

PEFLEX dampers mounted directly before the diffuser are used to **smoothly regulate the air flow and suppress noise in ventilation systems**. They are used both on supply and exhaust ducts.



### Key features

They allow for **convenient and smooth airflow adjustment** without removing the damper from the duct. It is enough to turn the lower ring to expose the oval pass-through openings.

**They are especially useful** when the air flow in a given point is too high and **the regulation with a diffuser** is impossible or generates a lot of noise.

They are equipped with **additional pass-through holes** intended for removal in case the user wants to achieve maximum airflow.

They are made of a special flexible acoustic foam with very high damping properties.

**They are very easy to install** directly in front of the diffuser.

Diameter	Thickness
Ø100/125/160 mm	40 mm

## PEFLEX PREMIUM air diffusers

PEFLEX PREMIUM supply and exhaust diffusers, as the end point of the air distribution system in mechanical ventilation installation, ensure **proper air distribution** in rooms. Our modern design allows you to choose the shape and color of the air diffusers.

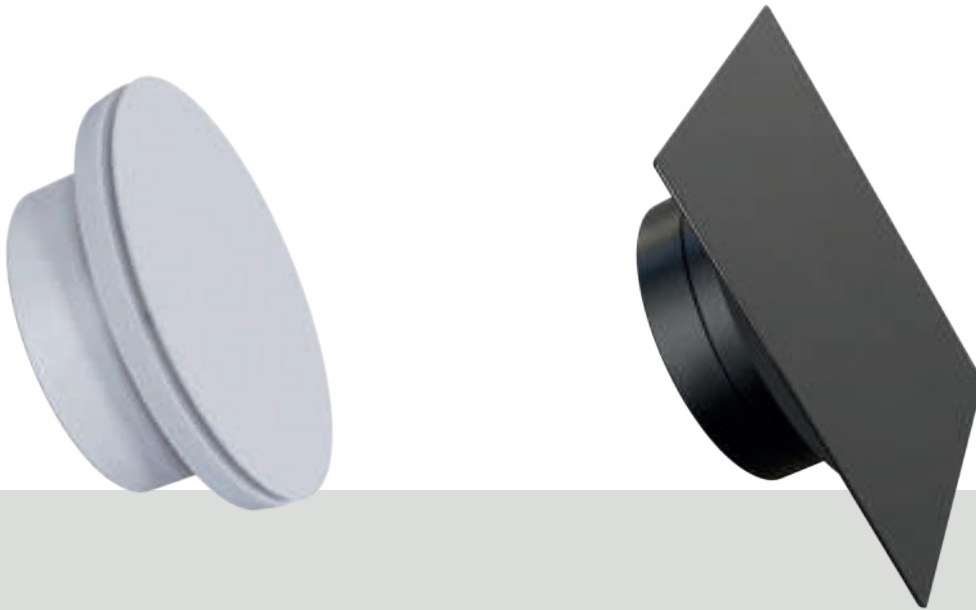

### Key features

**Modern Look.** The matte finish perfectly complements contemporary home interiors.

The selection of shapes and colors for the diffusers allows them **to match even the most demanding and sophisticated interior design projects.**

The new design not only offers a modern appearance but also features ergonomic construction that directs airflow to reduce the amount of dirt accumulating on the ceiling around ventilation points.

The smooth system adjustment and easy push-fit installation with a gasket facilitate installation work and system adjustment.

The ergonomic shape not only provides aesthetic appeal but also ensures **low noise levels and easy airflow measurement.**

The diffusers are available for plenum boxes with Ø125 mm connection spigots.

Available sizes:	Shapes:	Colors:
Ø 125 mm	round and square	Black and white



## Conical filters for diffusers

The conical filters for the diffuser are **installed directly within the air diffuser**, protecting the ventilation ducts from contamination. The shape of the cone reduces pressure loss of the flowing air, while maintaining a large filtration surface area.



### Key features

**They provide protection against contamination of the exhaust ductwork** and the entire recuperation system.

They are made of cone-shaped filter fabric that **traps dirt** such as dust, insects and grease.

The conical filters significantly **extend the working time** of the filters used in the recuperator.

**Direct installation above the diffuser allows for easy access and filter replacement.**

Available sizes:

Ø 80 mm

Ø 100 mm

Ø 125 mm

Ø 160 mm

Ø 200 mm

## PEFLEX Stainless steel intake/outlet grilles

Flat, square external grilles for the end of air intake and outlet ducts of recuperation systems, mounted on the external wall of the building or in the roof soffit.

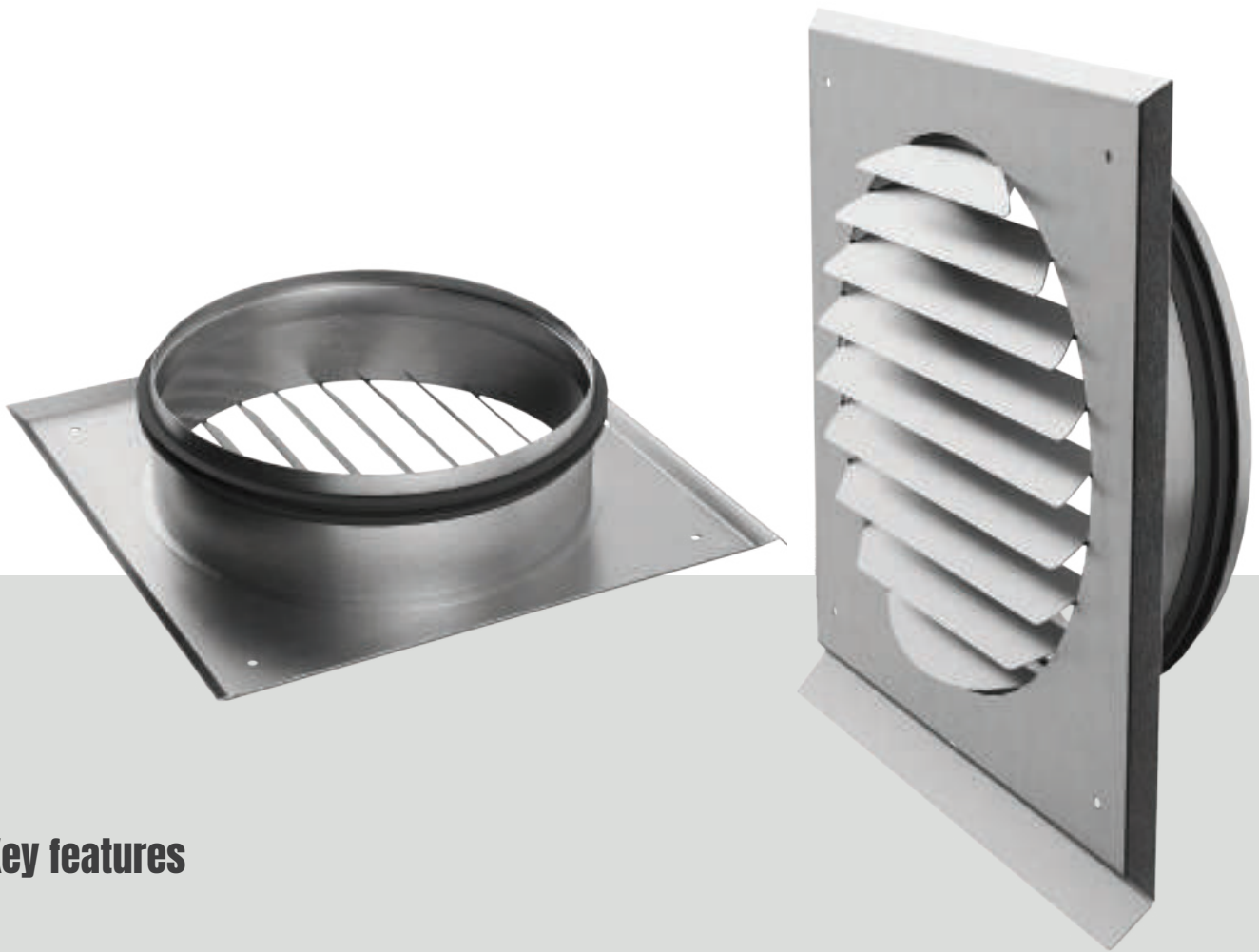

### Key features

The fins in the grille are designed to **minimize air resistance**.

They are made of **high quality stainless steel** for outdoor use without the risk of corrosion.

An additional drip cap protects the facade against stains.

A rubber gasket makes the air intake/outlet **easy to install** and protects against water leaking from the ventilation duct under the grille.

Sizes:	Ø160	Ø200	Ø250	Ø315
Colors:	Brushed stainless steel (Inox), Anthracite RAL7016, Black RAL9005, White RAL9016			

## Filters for recuperators

High quality replacement filters with improved parameters for e.g. Zehnder and KOMFOVENT recuperators. PEFLEX filters have a **number of improvements** to extend the operating time and improve tightness.



### Key features

**An increased filtration surface** compared to the original filters provide greater dust-holding capacity and extend the filter's service life, while maintaining low air resistance.

The rigid and durable cardboard filter frame, along with the foam gasket, ensures a high level of sealing for the filter installed in the recuperator.

**Enhanced filtration class** compared to the originals. The filters are available in three

filtration classes: **G4 - standard coarse filter, M5 - with improved filtration parameters, and F7 - pollen filter.**

**They are easy to use and replace**, featuring convenient and durable handles for filter removal and a clear arrow indicating the airflow direction.

Our filters are **fitted for the most popular models such as Zehnder and KOMFOVENT** recuperators.

Available in three filtration classes:

G4

M5

F7

## NEW! Insulated PEFLEX EPS 2025 Air Distribution System

The new, improved PEFLEX EPS air distribution system is an innovative way to combine high installation aesthetics with fast installation speed and excellent duct insulation. The EPS system is used to connect the recuperator to distribution boxes, as well as intake and outlet grilles, ensuring a tight and thermal-bridge-free connection.

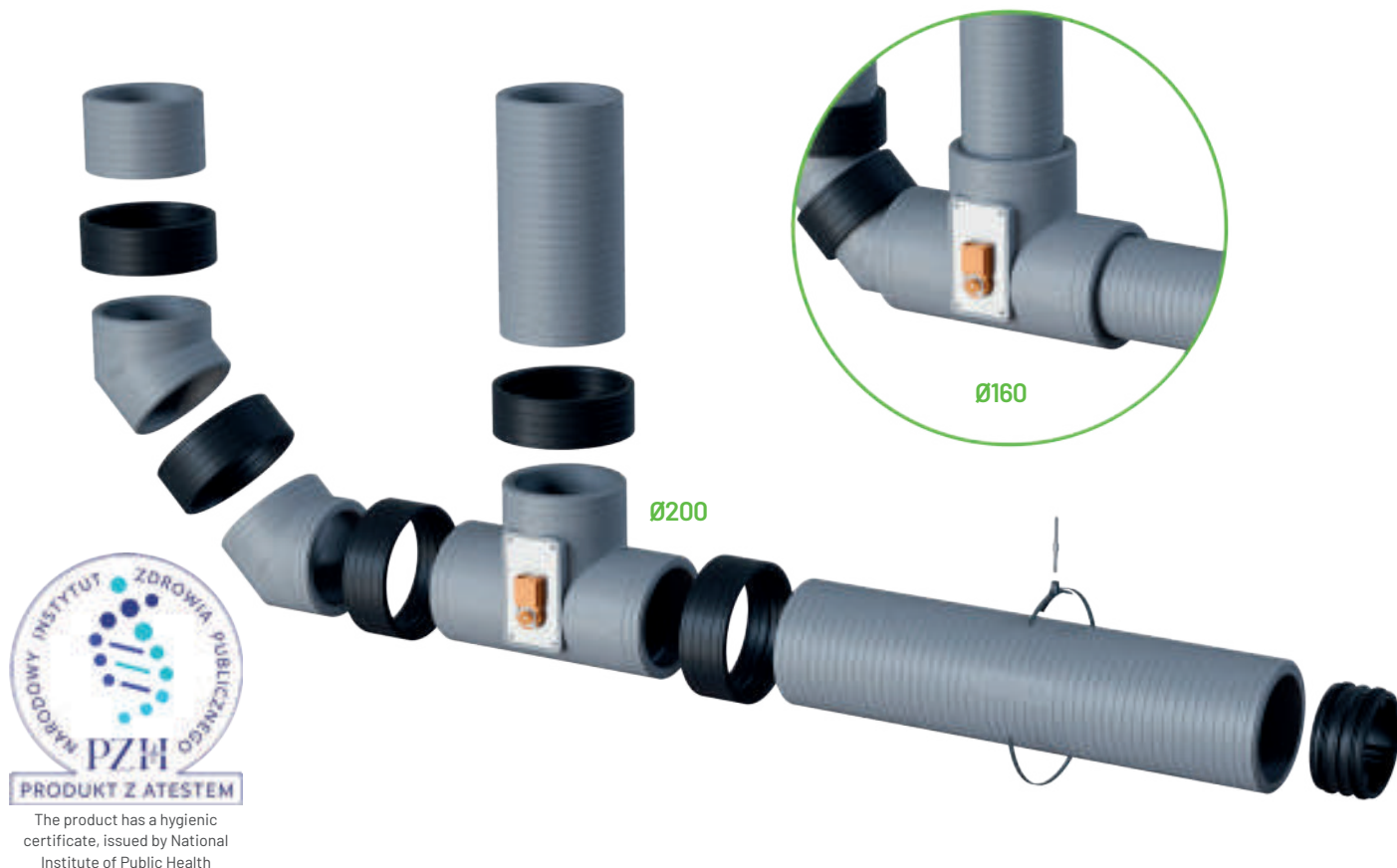

### Key features of the new system:

- **Available in two diameters:** Ø160 mm and Ø200 mm, which increases the flexibility of application in ventilation systems.
- **Innovative elastic EPP sockets:** provide tightness **without any adhesives, silicone, or acrylic**. This makes the push-fit assembly process faster, while the system maintains long-lasting airtightness.
- **One piece construction:** all elements and fittings are made **from a single piece of material**, which **eliminates the risk of elements separating** and increases their durability and tightness.

The PEFLEX EPS air distribution system was designed to minimise heat loss in the building and to enable bridgeless routing of ventilation ducts between the recuperator and the air intake and outlet grilles. Thanks to the use elastic EPP sockets, the connection process is fast, with no need to use professional equipment or additional sealing.

**The PEFLEX EPS 2025 Air Distribution System equals innovation, durability, and energy efficiency in one. Choose the modern solution for your ventilation system.**

## Advantages of the PEFLEX EPS 2025 System

### Up to 25% greater insulation:

(thermal resistance) compared to flexible and rigid ducts insulated with wool of the same thickness.

### Reduced installation costs:

Unlike metal ducts that require additional insulation, the PEFLEX EPS system installs faster, eliminating the need for extra materials and labor.

### Compatibility:

Seamless integration with other steel and flexible duct systems for versatile application.

### Faster installation:

Eliminating the need for additional insulation cuts installation time in half.

### Lightweight:

8 times lighter than insulated steel ducts, making transportation and installation easier.

### Moisture resistance:

The EPS material's high resistance to moisture and water ensures durability, consistent insulation performance, and eliminates the risk of moisture-related degradation.

### Lower airflow resistance:

Improved ventilation efficiency and reduced energy consumption compared to insulated flexible ducts.

### No thermal bridges:

Continuous, airtight insulation across the entire system thanks to flexible sockets and monolithic component construction.

### Self-sealing sockets

Push-fit airtight connection: No adhesives, silicone, or acrylic required, simplifying and speeding up the installation process.

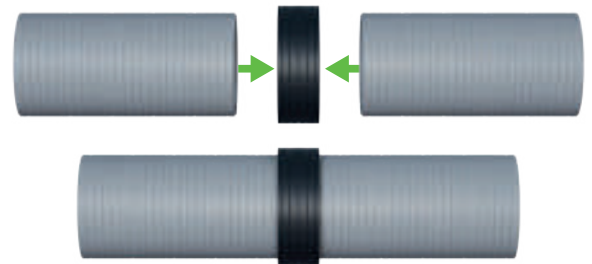

### Easy diameter changes

Reduce diameter from Ø200 mm to Ø160 mm by simply inserting the smaller duct into the larger one – no additional fittings required.

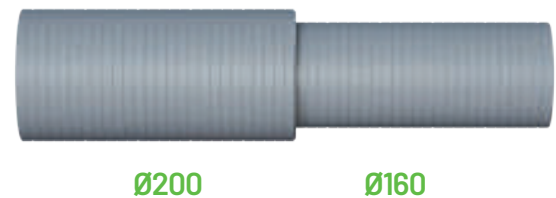

### Universal tee fitting

Connects PEFLEX EPS ducts of Ø160/200 mm and Ø200/250 mm in various configurations using a single fitting.

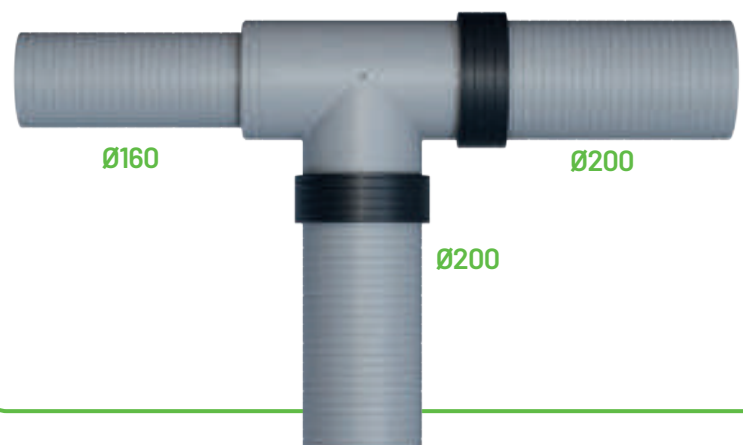

## ELEMENTS OF THE PEFLEX EPS 2025 SYSTEM

### PEFLEX EPS ducts with an internal diameter of Ø160 mm and Ø200 mm and a length of 100 cm



PEFLEX EPS rigid ducts are designed for air distribution in mechanical ventilation systems with heat recovery. Their 20 mm (Ø160) and 25 mm (Ø200) thick walls provide high thermal insulation. The monolithic, injection-molded construction eliminates the risk of leaks and ensures durability and high resistance to mechanical damage.

---

### PEFLEX EPS 45° elbows with an internal diameter of Ø160 mm and Ø200 mm



Durable and monolithic EPS 45° elbows allow to create bends in the ventilation system. Their compact design enables tight 90° turns by connecting two pieces. The smooth interior surface and specially designed profile minimize air resistance, ensuring smooth flow and high efficiency.

---

### PEFLEX EPP sockets to connect elements of the PEFLEX EPS system



PEFLEX EPP sockets enable fast and secure connections for PEFLEX EPS system components. The flexible, self-sealing material eliminates the need for additional sealants, ensuring easy installation and disassembly. Available in Ø200 for Ø160/200 mm EPS components and Ø250 for Ø200/250 mm components.

---

### PEFLEX EPS tee fitting and damper



This universal tee fitting connects Ø160 mm PEFLEX EPS ducts (directly) and Ø200 mm (using sockets) to split airflow. The damper version allows for actuator installation and airflow control (e.g., in GHE systems).

---

### PEFLEX EPP Ø198 mm nipple



Connects standard Ø200 mm metal and flexible ducts to the PEFLEX EPS Ø200/250 mm system without creating a thermal bridge.



# REQNET

New generation  
of intelligent recuperators



## reQ series recuperators

The REQNET recuperators are designed **to provide maximum indoor air comfort with minimal primary energy consumption**, while maintaining the highest levels of comfort. For this reason, all models feature intelligent control with built-in CO<sub>2</sub> and humidity sensors to automatically adjust the ventilation level in the building, while the internet connectivity allows the recuperator to be controlled also outside the home via a mobile app. To maintain the highest air quality, the units can be equipped with an anti-smog or anti-dust filter and an enthalpy heat exchanger (ERV) to minimise the drying out of the air in the building in winter.



## Features

**The use of an enthalpy exchanger** (ERV models) with an innovative polymer membrane that recovers moisture from the exhaust air will maintain maximum air quality comfort at your home.

**Smart control**, based on built-in CO<sub>2</sub> and humidity sensors, automatically adjusts the ventilation level to ensure your comfort while optimizing electricity consumption.

**Built-in Wi-Fi module** connected to home internet network allows you to control the recuperator via the Internet using a mobile device from anywhere in the world.



**The recuperator's insulation** made of polyethylene foam provides excellent acoustic and thermal insulation with no thermal bridges, as well as low weight.

**The use of the latest technologically advanced EBM-Papst DC radial fans**, combined with a constant airflow system, ensures low energy consumption and quiet operation of the recuperator.

**The innovative dual air filtration system**, equipped with a high-efficiency F9 filter that protects against smog, is the only one in its class to provide true health protection for your family.

**Extensive automation** will enable you to integrate the recuperator into your smart home system and connect a range of optional peripherals.

## New level of standard features in recuperators

We want you to enjoy all the benefits we offer. That's why, when you choose our product, you receive a fully equipped unit with no additional costs. Enjoy it to the fullest, without compromise.



Wi-Fi module



EC fans



constant flow system



built-in CO<sub>2</sub> sensor



built-in humidity sensor



PTC preheater

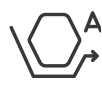

100% automatic bypass



mobile app



assembly system



dry siphon



extensive automation



anti smog filter

## Control the recuperator via your phone

Each unit is equipped with a Wi-Fi module that connects to your home internet, allowing convenient control of the device via your smartphone by any household member—whether you're on the couch or even on the other side of the world!

The REQNET app provides complete management of your recuperator, without the need to install additional wall controllers. It allows you to control multiple operating modes of the unit and allows you to view the current operating parameters remotely.



## reQ V.400/550 recuperators

The recuperators of the reQ V series are units with top-mounted spigot exits, designed for wall-mounted installation. The robust stainless steel casing and excellent acoustic and thermal insulation through the use of polyethylene foam make them ideal for installation in domestic utility rooms. The use of one of the largest counter-flow heat exchangers in this class of recuperators with a surface area of 35 m<sup>2</sup> ensures high heat recovery. The reQ V. recuperators are available in two versions with capacities of 400 and 550 m<sup>3</sup>/h and can have an optional moisture recovery exchanger (ERV).

### Available versions:

counterflow with heat recovery

**reQ V.400 HRV**

**reQ V.550 HRV**

enthalpic counterflow with heat and moisture recovery

**reQ V.400 ERV**

**reQ V.550 ERV**

### Easy and quick installation

Thanks to its unique flat construction with a laterally placed heat exchanger, the reQ V. recuperator protrudes from the wall by only 47 cm! This allows the recuperator to be conveniently mounted in narrow rooms or garages.

The reQ V. series recuperator is mainly designed for wall mounting in technical rooms. The original stainless steel mounting bracket included as standard allows the unit to be hung on the wall in a fast and stable manner.

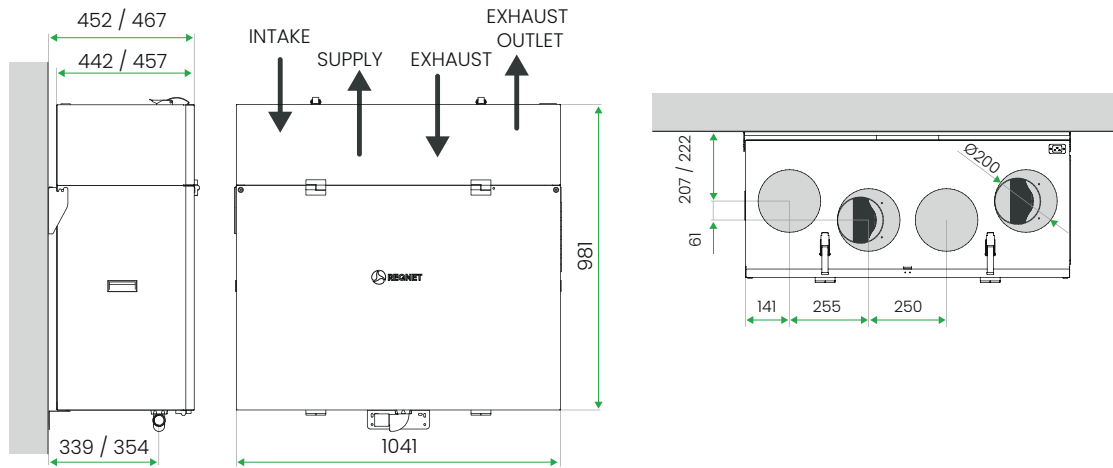

**Dimensions:**

Model	reQ V.400 HRV / ERV		reQ V.550 HRV / ERV	
<b>Maximum air flow</b>	400 m³/h*	at 150 Pa (HRV) at 180 Pa (ERV)	550 m³/h*	at 150 Pa (HRV) at 180 Pa (ERV)
<b>Heat recovery efficiency</b>	up to 95% (HRV) / up to 85% (ERV)			
<b>Exchanger type</b>	counterflow			
<b>Exchanger variant</b>	HRV: with heat recovery ERV: with heat and moisture recovery (enthalpy)			
<b>Exchanger material</b>	HRV: plastic ERV: plastic + polymer membrane			
<b>Moisture recovery efficiency</b>	No (HRV) / up to 65% (ERV)			
<b>Energy consumption</b>	100 m³/h (50 Pa)	25 W (HRV)	200 m³/h (50 Pa)	43 W (HRV)
		24 W (ERV)		42 W (ERV)
	250 m³/h (100 Pa)	74 W (HRV)	400 m³/h (100 Pa)	157 W (HRV)
		72 W (ERV)		154 W (ERV)
	400 m³/h (150 Pa)	187 W (HRV)	550 m³/h (150 Pa)	272 W (HRV)
		184 W (ERV)		267 W (ERV)
<b>The sound power level emitted by the housing at a distance of 1 meter</b>	100 m³/h (50 Pa)	24 db(A)	200 m³/h (50 Pa)	30 db(A)
	250 m³/h (100 Pa)	33 db(A)	400 m³/h (100 Pa)	42 db(A)
	400 m³/h (150 Pa)	43 db(A)	550 m³/h (150 Pa)	48 db(A)
<b>Sound power level - nominal value</b>	35 db(A)		41 db(A)	
<b>Fans</b>	radial with EC DC motors (ebm - papst)			
<b>Energy efficiency class</b>	A**			
<b>Bypass</b>	automatic, 100% supply air bypass			
<b>Communication</b>	built-in wi-fi module control via a mobile application (iOS 12.0 and Android 8.0 or newer) or web browser			
<b>Cooperation with the smart home system</b>	YES (REST API LOXONE)			
<b>Diameter of connection spigots</b>	4 x Ø200 mm			
<b>Filters</b>	pleated class M5*** / ePM10 75% **** (optionally air vent: anti-smog F9*** / ePM1 80%****)			
<b>Pre-heater</b>	built-in, smoothly controlled PTC			
<b>Constant Flow System</b>	YES			
<b>Humidity sensor</b>	YES, built-in			
<b>O2 Sensor</b>	YES, built-in			
<b>Casing material</b>	Stainless			
<b>Dimensions (H x W x D)</b>	981 x 1041 x 442 mm			

\* with an M5 class filter

\*\* for a temperate climate in accordance with Directive 2009/125/EC and European Commission Regulation No. 1254/2014

\*\*\* according to EN779

\*\*\*\* according to ISO 16890

## reQ H.400/500 recuperators

The recuperators of the reQ H. series are floor-standing units with lateral spigot exits with the additional option of hanging on the wall. The slim and robust stainless steel casing and excellent acoustic and thermal insulation, thanks to the use of polyethylene foam, make them ideal for installation, for example in domestic attics. The use of one of the largest counterflow heat exchangers in this class of recuperators with a surface area of 35 m<sup>2</sup> ensures high heat recovery. The reQ H. recuperators are available in two versions with capacities of 400 and 500 m<sup>3</sup>/h and can have an optional moisture recovery exchanger (ERV).

### Available versions:

counterflow with heat recovery

reQ H.400 HRV

reQ H.500 HRV

enthalpic counterflow with heat and moisture recovery

reQ H.400 ERV

reQ H.500 ERV

### Easy and quick installation

Thanks to the unique slim design with a transversely located heat exchanger, **the width of the reQ H. unit is only 44 cm, and just 37 cm** with the covers removed. This allows the unit to be inserted even through the narrowest openings, such as a small attic hatch.

The reQ H. series recuperator is mainly designed for standing installation in attics and technical rooms. Dedicated legs allow the recuperator to be placed stably on the floor and to easily connect the condensate drain.

**Wall mounting of the recuperator is also possible using the original stainless steel mounting bracket.**



Dimensions:

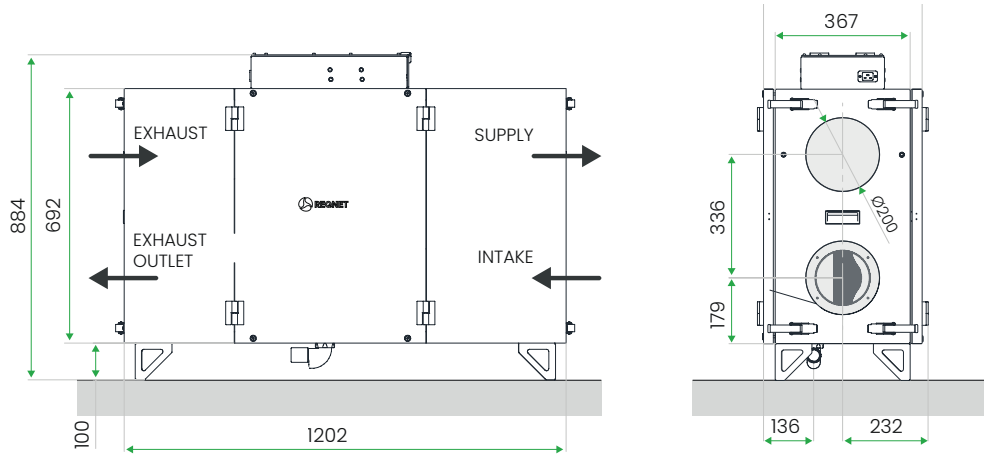

Model	reQ H.400 HRV / ERV		reQ H.500 HRV / ERV	
<b>Maximum air flow</b>	400 m³/h*	at 150 Pa (HRV) at 200 Pa (ERV)	500 m³/h*	at 150 Pa (HRV) at 200 Pa (ERV)
<b>Heat recovery efficiency</b>	up to 95% (HRV) / up to 85% (ERV)			
<b>Exchanger type</b>	counterflow			
<b>Exchanger variant</b>	HRV: with heat recovery ERV: with heat and moisture recovery (enthalpy)			
<b>Exchanger material</b>	HRV: plastic ERV: plastic + polymer membrane			
<b>Moisture recovery efficiency</b>	No (HRV) / up to 65% (ERV)			
<b>Energy consumption</b>	100 m³/h (50 Pa)	23 W (HRV) 21 W (ERV)	200 m³/h (50 Pa)	42 W (HRV) 39 W (ERV)
	250 m³/h (100 Pa)	68 W (HRV) 65 W (ERV)	400 m³/h (100 Pa)	143 W (HRV) 140 W (ERV)
	400 m³/h (150 Pa)	170 W (HRV) 167 W (ERV)	500 m³/h (150 Pa)	267 W (HRV) 261 W (ERV)
<b>The sound power level emitted by the casing at a distance of 1 meter</b>	100 m³/h (50 Pa)	30 db(A)	200 m³/h (50 Pa)	38 db(A)
	250 m³/h (100 Pa)	41 db(A)	400 m³/h (100 Pa)	47 db(A)
	400 m³/h (150 Pa)	48 db(A)	500 m³/h (150 Pa)	51 db(A)
<b>Sound power level - nominal value</b>	41 db(A)		45 db(A)	
<b>Fans</b>	radial with EC DC motors (ebm - papst)			
<b>Energy efficiency class</b>	A**			
<b>Bypass</b>	automatic, 100% supply air bypass			
<b>Communication</b>	built-in wi-fi module control via a mobile application (iOS 12.0 and Android 8.0 or newer) or web browser			
<b>Cooperation with the smart home system</b>	YES (REST API LOXONE)			
<b>Diameter of connection spigots</b>	4 x Ø200 mm			
<b>Filters</b>	pleated class M5*** / ePM10 75% **** (optionally air vent: anti-smog F9*** / ePM1 80%****)			
<b>Pre-heater</b>	built-in, smoothly controlled PTC			
<b>Constant Flow System</b>	YES			
<b>Humidity sensor</b>	YES, built-in			
<b>CO2 Sensor</b>	YES, built-in			
<b>Casing material</b>	stainless			
<b>Dimensions (H x W x D)</b>	784 x 1202 x 432 mm			

\* with an M5 class filter

\*\* for a temperate climate in accordance with Directive 2009/125/EC and European Commission Regulation No. 1254/2014

\*\*\* according to EN779

\*\*\*\* according to ISO 16890

## reQ F.350 ERV recuperators

The recuperators of the reQ F.350 ERV series feature an ultra-slim design, allowing for installation on the ceiling, floor, or wall without the need for a condensate drain connection. They feature an enthalpy heat exchanger with moisture recovery (ERV) as standard to ensure an optimum building climate all year round and minimise the drying out of building air in winter. The robust stainless steel construction and excellent acoustic and thermal insulation thanks to the PE foam filling ensure that the recuperators can even be installed in suspended ceilings. The reQ F. units are available with a capacity of 350 m<sup>3</sup>/h.

### Available versions:

reQ F.350 ERV

### Easy and quick installation

Thanks to its unique low design with a special flat heat exchanger, the height of the reQ F. is only 26 cm! As a result, the ceiling-mounted recuperator takes up very little space and will even fit into small false ceiling spaces.

The unit does not have a condensate drain, so it can be installed practically anywhere in the house. This facilitates the planning of installations in already inhabited buildings or those without a garage or a dedicated boiler room.

A dedicated stainless steel mounting bracket allows for very easy and stable installation under the ceiling or on the wall.



Dimensions:

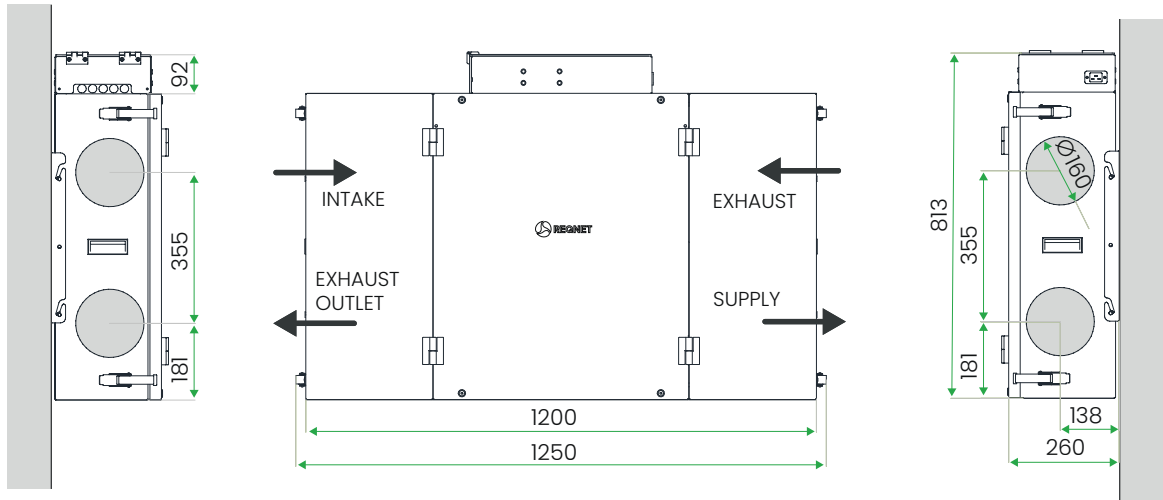

Model	reQ F.350 ERV	
Maximum air flow	350 m <sup>3</sup> /h at 150 Pa*	
Heat recovery efficiency	up to 85%	
Exchanger type	counterflow	
Exchanger variant	ERV: with heat and moisture recovery (enthalpy)	
Exchanger material	plastic + polymer membrane	
Moisture recovery efficiency	up to 65%	
Energy consumption	100 m <sup>3</sup> /h (50 Pa)	33 W
	175 m <sup>3</sup> /h (100 Pa)	68 W
	350 m <sup>3</sup> /h (150 Pa)	270 W
The sound power level emitted by the casing at a distance of 1 meter	100 m <sup>3</sup> /h (50 Pa)	29 dB(A)
	175 m <sup>3</sup> /h (100 Pa)	38 dB(A)
	350 m <sup>3</sup> /h (150 Pa)	53 dB(A)
Sound power level - nominal value	46 dB(A)	
Fans	radial with EC DC motors (ebm - papst)	
Energy efficiency class	A**	
Bypass	automatic, 100% supply air bypass	
Communication	built-in wi-fi module control via a mobile application (iOS 12.0 and Android 8.0 or newer) or web browser	
Cooperation with the smart home system	YES (REST API LOXONE)	
Diameter of connection spigots	4 x Ø160 mm	
Filters	pleated class M5*** / ePM10 75% **** (optionally air vent: anti-smog F9*** / ePM1 80%****)	
Condensate drain	not equipped	
Pre-heater	built-in, smoothly controlled PTC	
Constant Flow System	YES	
Humidity sensor	YES, built-in	
CO2 Sensor	YES, built-in	
Casing material	stainless	
Dimensions (H x W x D)	810 x 1210 x 260 mm	
Weight	42 kg	
Equipment	optional F9 anti-smog filter	
	Stainless steel mounting bracket for wall/ceiling installation	

\* with an M5 class filter

\*\* for a temperate climate in accordance with Directive 2009/125/EC and European Commission Regulation No. 1254/2014

\*\*\* according to EN779

\*\*\*\* according to ISO 16890

## izzi H.302 ERV recuperators with enthalpy heat exchangers



**izzi H.302 ERV** are compact recuperators with a **modern enthalpy exchanger** with an innovative polymeric membrane, which allows to recover, apart from **heat energy**, **also moisture and latent energy**. Extensive automation as standard and many control modes allow for **simple and convenient control** of the recuperator. Ideally **suited for installation in places where it was previously impossible**, such as apartments, finished houses or even in living spaces such as above the false ceiling.

### Key features

**The highest level of equipment** in this class of recuperators, based on our own dedicated solutions and components from renowned global suppliers. Additionally, the recuperator can be easily and quickly expanded with modules increasing its functionality.

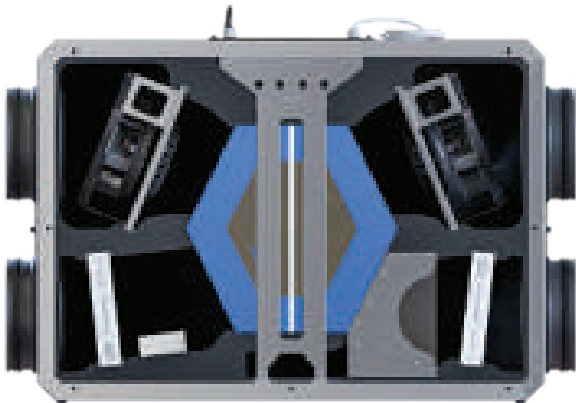

EC fans



control panel



constat flow system (optional)



built in CO<sub>2</sub> sensor (optional)



built in humidity sensor (optional)



extensive automation



100% automatic bypass



universal assembly system



antismog filter



no condensation



They come standard with an **enthalpic counterflow heat exchanger** with moisture recovery, which ensures efficient heat and moisture recovery, including latent energy. It features the absence of a condensate drain and the ability to operate in subzero outdoor temperatures without the need for an additional preheater.

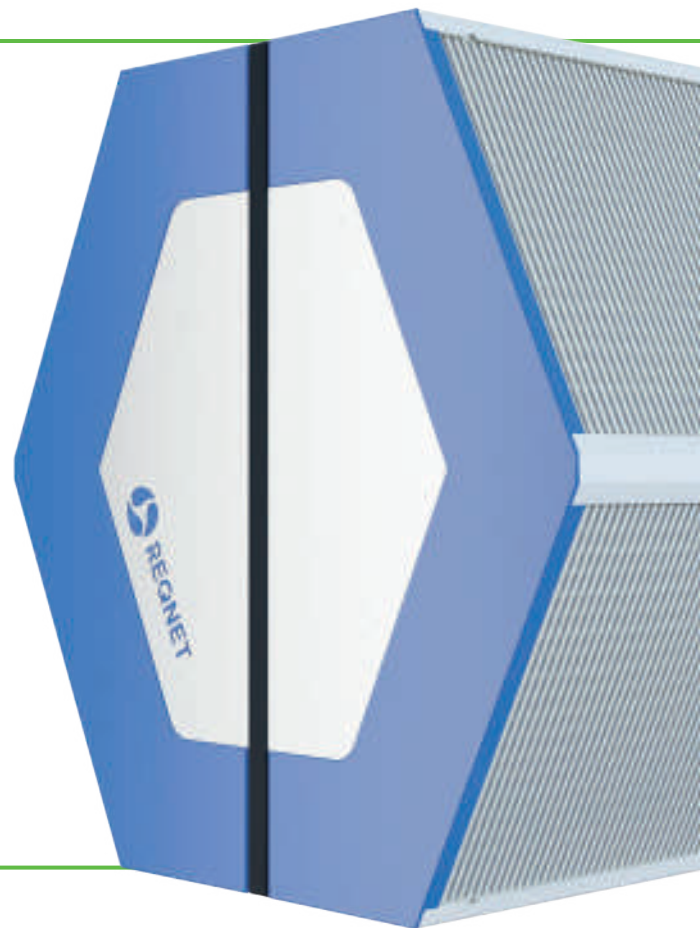
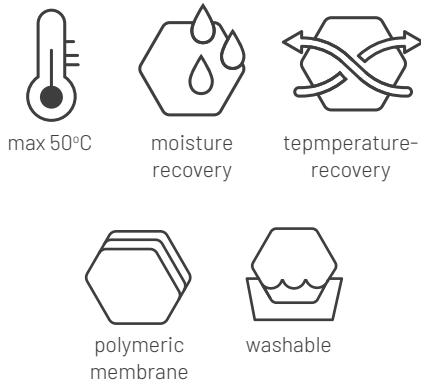

## Control

The Wi-Fi module in the izzi H.302 ERV CONNECT recuperator is an element which enables remote control of the unit via a modern mobile application.

**The izzi CONNECT application allows, among others, for:**

- changing the performance and operating modes of the unit,
- setting the operating schedule,
- viewing the temperature at the inlet, outlet, supply and exhaust,
- viewing the air humidity and CO<sub>2</sub> concentration in the house (with the hygro/CO<sub>2</sub> module),
- reading the current air exchange in m<sup>3</sup>/h (with the constant flow module),
- activating additional operating modes, i.e. ventilation, fireplace, outside the home,
- controlling unit operation parameters (automatic bypass, comfort temperature, etc.),
- management and control of peripheral equipment (i.e. GHE, coolers and heaters),
- supply/exhaust capacity correction.



**Universal installation in any position:** under the ceiling, on the wall or on the floor, but also in the living space, for example above the false ceiling.

### Wall mounting

Low weight and dedicated mounting bracket makes it easy to hang the recuperator on the wall **even by one person**.



### Ceiling mounting

The included mounting bracket allows you to **quickly and securely** install the device on the ceiling, where it does not take up additional space.



### Floor mounting

No condensate drain makes it possible to set the device on the floor, without using additional legs.

### Horizontal installation

In this position, the unit can be installed in **really tight spaces** or low attics- only service access must be provided.

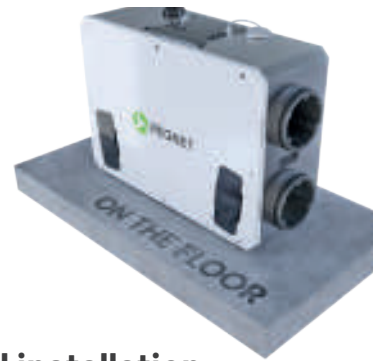

Possibility to **expand the recuperator** with additional modules:

- **Constant flow module** - ensuring **automatic balancing** of the supply and exhaust flow in the ventilation system.
- **CO<sub>2</sub>/hygro measuring module** with a carbon dioxide and humidity sensor enabling **automatic control** of recuperator's efficiency on the basis of the air quality in the house, ensuring optimal operation of the unit adjusted to a given situation - without the user's interference.

Energy-saving DC fans with reduced noise emission and PE foam insulation allow to maintain **excellent acoustic properties** of the recuperator.

**Effective filtration** of supply air using a pleated filter with a high M5 filtration class.

**Compact casing** made of stainless steel, **convenient assembly console** and **two versions** of recuperator: left and right allow for flexible installation, even in small spaces.

Dimensions:

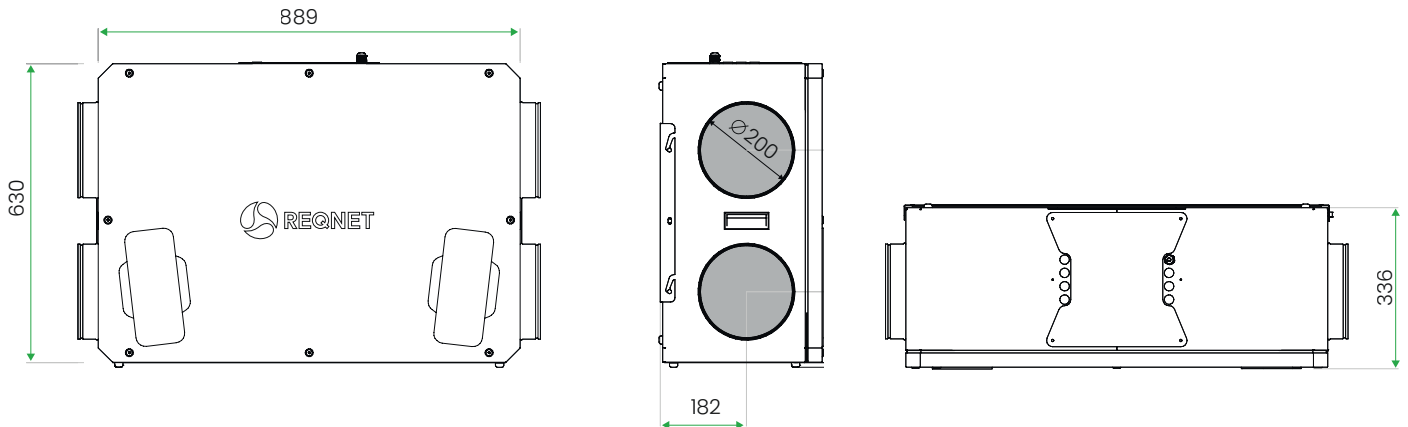

Model	izzi H.302 ERV		
Maximum air flow	300 m <sup>3</sup> /h at 150 Pa		
Heat recovery efficiency	up to 85%		
Exchanger type	counterflow		
Exchanger variant	enthalpy (with moisture recovery)		
Exchanger material	plastic + polymer membrane		
Moisture recovery efficiency	up to 65%		
Maximum fan power	165 W		
Gears	I gear (90 m <sup>3</sup> /h at 30 Pa)	II gear (180 m <sup>3</sup> /h at 100 Pa)	III gear (300 m <sup>3</sup> /h at 150 Pa)
Energy consumption	26 W	60 W	165 W
The sound power level emitted by the casing at a distance of 1 meter	30 dB(A)	39 dB(A)	46 dB(A)
Sound power level - nominal value	39 dB(A)		
Fans	radial Radical with DC EC motor		
Energy efficiency class	A*		
Bypass	automatic, isolated, 100% supply air bypass		
Anti-freeze system	vacuum, operating only below the temperature of -7°C		
Controller	LCD 3.2" with color touchscreen (STANDARD) or via a mobile app (Android 8.0 or newer) iOS in preparation - details coming soon (CONNECT)		
Connecting the controller to the device	Shielded cable 4x0,5 ** - 3 metres included (STANDARD)		
Filters	pleated class 4x0,5*** / M5 **** H.302		
Diameter of connection spigots	4 x Ø200 mm		
Condensate drain	not equipped		
Protection rating	IP 40		
Insulation class of the device	I		
Temperature measurement tolerance	+/- 2°C		
Supply voltage	230V (AC), 50Hz		
Weight (with dedicated rack)	26+2 kg		
Dimensions (H x W x D)	336 x 889 x 630 mm		

\* for a temperate climate in accordance with Directive 2009/125/EC and European Commission Regulation No. 1254/2014

\*\* over 10 m length recommended 4x0.75 (shielded)

\*\*\* according to ISO 16890

\*\*\*\* according to EN779

## Izzi V.302 ERV and Izzi V.402 ERV recuperators

izzi V 302/402 ERV are **compact recuperators** with an innovative and modular design. **They consist of two independent but interconnected parts:** the upper and lower part, which enable installation by one person and easy service access. **Compact dimensions** allow the unit to be mounted in small spaces, even in a closet, **above a washing machine or refrigerator.**



## Key features

The modular construction of the recuperator **allows easy access for operation and maintenance of the unit**, which consists of two parts:

- The upper part, where the heart of the unit is located, namely: automatics, filters with an external inspection opening and EC fans.
- The lower suspended part containing the permanent enthalpy exchanger, designed to recover heat and moisture along with hidden energy from the air removed from the rooms.



### The izzi V.402 ERV recuperators, like the V.302 ERV, feature:

- The highest level of equipment in this class of recuperators, based on its own dedicated solutions and components from renowned global suppliers. Additionally the recuperator can be **easily and quickly extended** by **modules** increasing its functionality.
- **Enthalpy counterflow heat exchanger** with polymeric membrane as a standard, is characterized by **high heat and moisture recovery with latent energy, no condensate outflow and the possibility of operation even at negative outdoor temperatures without an additional pre heater.**

### Possibility to expand the recuperator with additional modules:



**CO<sub>2</sub>/hygro measuring module with a carbon dioxide and humidity sensor** - enabling automatic control of recuperator's efficiency on the basis of the air quality in the house, ensuring optimal operation of the unit adjusted to a given situation - without the user's interference.



**Constant flow module** - ensuring automatic balancing of the supply and exhaust flow in the ventilation system.

- **Universal assembly** in vertical position: on the wall or on the floor.
- **Energy efficient** DC fans with reduced noise emission and PE foam insulation allow to keep perfect acoustic properties of the recuperator.
- **Efficient filtration** of supply air by means of pleated filter of high filtration class M5.
- **Compact casing** made of stainless steel and the convenient mounting bracket allow for efficient installation even in small spaces.

**The very compact unit dimensions**, measuring 600x600x750 mm, enable installation in places where it was previously not possible, such as in a built-in closet, above a washing machine, or refrigerator. Additionally, **the quiet operation of the unit**, thanks to the use of special foam insulation and modern DC motors, allows for the placement of the heat recovery unit in living spaces.



## Control

The Wi-Fi module in the izzi H.302 ERV CONNECT recuperator is an element which enables remote control of the unit via a modern mobile application.



**The izzi CONNECT application allows, among others, for:**

- changing the performance and operating modes of the unit,
- setting the operating schedule,
- viewing the temperature at the inlet, outlet, supply and exhaust,
- viewing the air humidity and CO2 concentration in the house (with the hygro/CO2 module),
- reading the current air exchange in m<sup>3</sup>/h (with the constant flow module),
- activating additional operating modes, i.e. ventilation, fireplace, outside the home,
- controlling unit operation parameters (automatic bypass, comfort temperature, etc.),
- management and control of peripheral equipment (i.e. GHE, coolers and heaters),
- supply/exhaust capacity correction.

Dimensions:

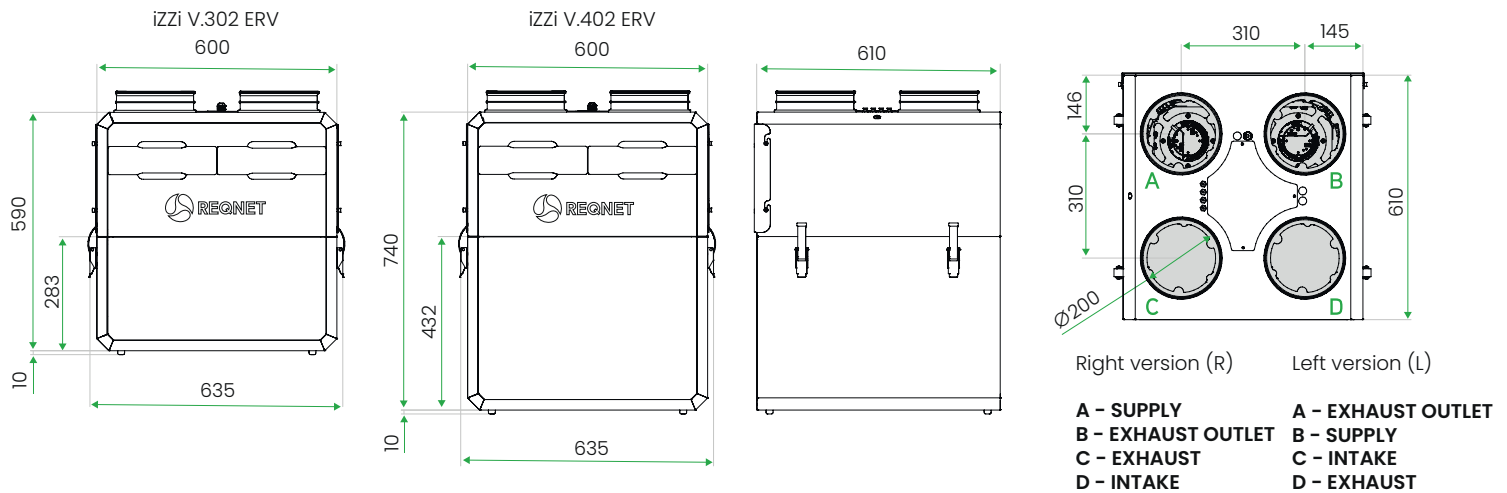

Model	izzi V.302 ERV			izzi V.402 ERV		
Maximum air flow	300 m <sup>3</sup> /h at 150 Pa			400 m <sup>3</sup> /h at 150 Pa		
Heat recovery efficiency	up to 85%					
Exchanger type	counterflow					
Exchanger variant	Enthalpy (with moisture recovery)					
Exchanger material	plastic + polymer membrane					
Moisture recovery efficiency	up to 65%					
Maximum fan power	165 W			210 W		
Gears	I gear - 30% (90 m <sup>3</sup> /h at 50 Pa)	II gear - 60% (180 m <sup>3</sup> /h at 150 Pa)	III gear - 100% (300 m <sup>3</sup> /h at 50 Pa)	I gear - 30% (100 m <sup>3</sup> /h at 100 Pa)	II gear - 60% (250 m <sup>3</sup> /h at 100 Pa)	III gear - 100% (400 m <sup>3</sup> /h at 150 Pa)
Energy consumption	20 W	59 W	164 W	20 W	73 W	205 W
The sound power level emitted by the casing at a distance of 1 meter	dB(A)	35 dB(A)	43 dB(A)	28 dB(A)	38 dB(A)	48 dB(A)
Sound power level - nominal value	38 dB(A)			41 dB(A)		
Fans	radial Radical with DC EC motors					
Energy efficiency class	A*					
Bypass	automatic, isolated, 100% supply air bypass					
Anti-freeze system	vacuum, operating only below the temperature of -7°C					
Controller	LCD 3.2" with color touchscreen (STANDARD) or via a mobile app (Android 8.0 or newer) iOS in preparation - details coming soon (CONNECT)					
Connecting the controller to the device	Shielded cable 4x0,5 ** - 3 metres included (STANDARD)					
Filters	V.302/V.402 pleated class ePM10 ≥ 50%***/ M5****					
Diameter of connection spigots	4 x Ø200 mm					
Condensate drain	not equipped					
Protection rating	IP 40					
Insulation class of the device	I					
Temperature measurement tolerance	+/- 2°C					
Supply voltage	230V (AC), 50Hz					
Weight (with dedicated rack)	26 kg			36 kg		
Dimensions (H x W x D)	336 x 889 x 630 mm			750 x 635 x 610 mm		

\* for a temperate climate in accordance with Directive 2009/125/EC and European Commission Regulation No. 1254/2014

\*\* over 10 m length recommended 4x0.75 (shielded)

\*\*\* according to EN779

\*\*\*\* according to ISO 16890

## BASIC H.250 ERV recuperators

The **BASIC H.250 HRV recuperators** are the most compact in the range, designed for efficient ventilation of apartments and small houses. The units offer an excellent price-to-quality ratio, **combining modern components and thoughtful design with easy installation**, either on the wall or floor. Simple operation via a dedicated wall-mounted controller and an optional CO<sub>2</sub>/hygro module ensures user comfort and energy efficiency.

The recuperator is equipped with an electronic bypass that utilizes free cooling, and the energy-efficient, smoothly controlled PTC pre-heater allows the device to operate effectively during freezing temperatures. **The BASIC recuperator is the perfect choice for those seeking a reliable, easy-to-use ventilation system with modern solutions.**

### Key features:

- High heat recovery efficiency of up to 95% is achieved thanks to the counterflow HRV heat exchanger.
- New-generation, energy-efficient EC direct current fans provide high performance with low energy consumption.
- No internal thermal bridges thanks to advanced PE foam insulation.
- Built-in, smoothly controlled PTC pre-heater.
- Effective air filtration thanks to M5 class filters (ePM<sub>10</sub> 75%) with a large filtration surface area.
- Automatic control based on air quality thanks to the CO<sub>2</sub>/hygro module.
- Electronic bypass for optimal temperature management.
- Available in both left and right versions.

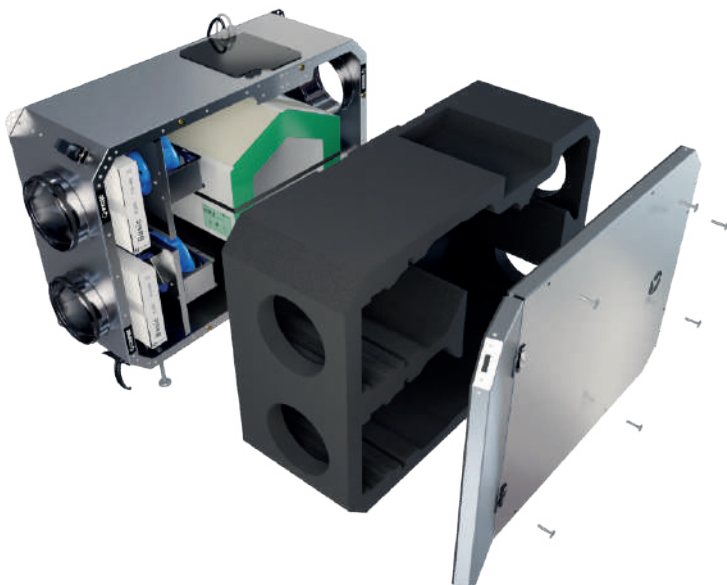

### Long-lasting durability and reliable performance.

The recuperator's casing is made of durable stainless steel, and the foam insulation guarantees **excellent thermal and acoustic insulation, eliminating heat loss**. The energy-efficient EC fans ensure quiet operation and low energy consumption, while the counterflow heat exchanger recovers up to 95% of energy.



Dimensions:

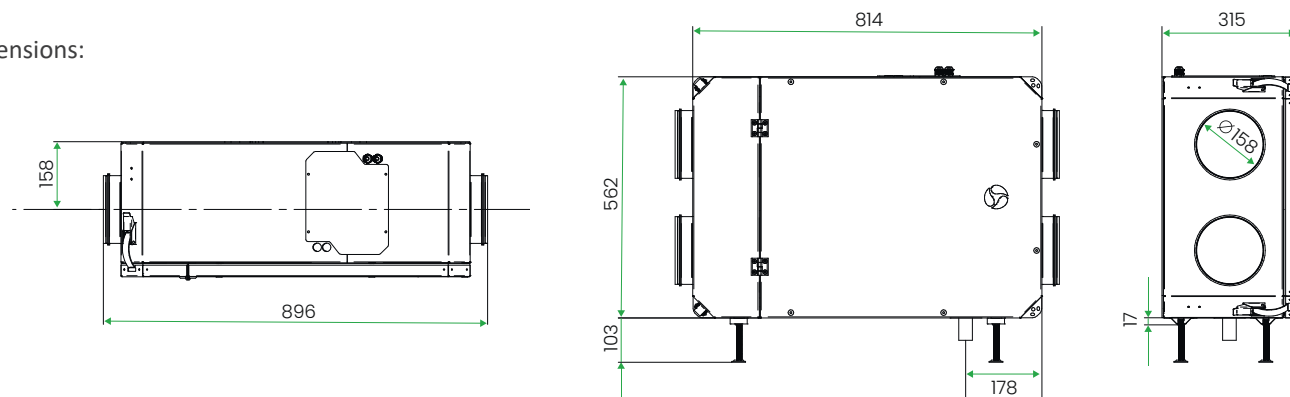

<b>Model</b>	BASIC H.250 HRV		
<b>Maximum air flow</b>	250 m <sup>3</sup> /h at 150 Pa		
<b>Heat recovery efficiency</b>	up to 95%		
<b>Exchanger type</b>	counterflow		
<b>Exchanger variant</b>	Standard - HRV		
<b>Exchanger material</b>	plastic		
<b>Moisture recovery efficiency</b>	-		
<b>Maximum fan power</b>	125 W		
<b>Gears</b>	50% (90 m <sup>3</sup> /h at 30 Pa)	75% (175 m <sup>3</sup> /h at 100 Pa)	100% (250 m <sup>3</sup> /h at 150 Pa)
<b>Energy consumption</b>	27 W	69 W	125 W
<b>Sound power level - nominal value</b>	41 dB(A)		
<b>Fans</b>	radial radial with DC EC motors		
<b>Energy efficiency class</b>	A*		
<b>Bypass</b>	automatic, electronic		
<b>Anti-freeze system</b>	1 kW pre-heater		
<b>Communication</b>	stepless control knob		
<b>Filters</b>	pleated filters class M5 / ePM10 75%		
<b>Connection spigots</b>	stainless steel 4xØ160 mm		
<b>Condensate drain</b>	Ø32 mm		
<b>Protection rating</b>	IP 40		
<b>Insulation class of the device</b>	I		
<b>Temperature measurement tolerance</b>	+/- 2°C		
<b>Supply voltage</b>	230V (AC), 50Hz		
<b>Casing material</b>	stainless steel		
<b>Weight</b>	20 kg		
<b>Dimensions (H x W x D)</b>	562 x 814 x 315 mm		
<b>Equipment</b>	wall-mounted controller with a 3-meter signal cable Connection stubs 4 xØ160 mm Power cable 2.8 m long Screw-in feet: M10, 4x100 mm		
<b>Optional peripheral devices</b>	CO <sub>2</sub> /hygro module momentary ventilation button Away function button / Alarm control panel		

\* for a temperate climate in accordance with Directive 2009/125/EC and European Commission Regulation No. 1254/2014

\*\* according to EN779

\*\*\* according to ISO 16890

## Equipment of the BASIC recuperator



EC fans



wall-mounted controller



built-in CO<sub>2</sub> and humidity sensor (optional)



dedicated automation



electronic by-pass



integrated mounting system



antismog box (optional)



counterflow heat exchanger HRV

## Filter boxes

The **izzi SF filter boxes**, with **dual filtration** (including an F9 class filter), provide **very high protection against smog** by purifying the incoming air by up to 96% (from PM10 smog particles). They also allow the use of pollen filters, which are particularly recommended for allergy sufferers. The boxes **can work with most recuperators available on the market**.



### Key features

The box has thermal insulation made of **water-resistant foam with additional soundproofing properties**.

The izzi SF box casing is **made entirely of corrosion-resistant brushed stainless steel**, and the special design ensures **high tightness** of filters and inspection flap.

The applied **double filtration** system provides protection even against the finest smog particles PM1 of size below 1 micrometer.

The filter box allows for **universal left or right installation**, giving great flexibility in the layout of the installation.

The izzi SF filter box is installed in the ductwork of the air intake or, in case of insufficient space or difficult access for filter replacement, it can be installed in the supply air duct.

Models:	izzi 160	izzi 200
Spigot dimension	Ø160	Ø200
Maximum airflow:	up to 250 m <sup>3</sup> /h	up to 550 m <sup>3</sup> /h

The izzi SF filter boxes have a **universal right or left-hand installation**. To change the direction of air flow simply swap and rotate the filters used, remembering that the M5 pre-filter always comes first.

LEFT-HAND MOUNTING



RIGHT-HAND MOUNTING



## Double filtration

Highly accurate filtration

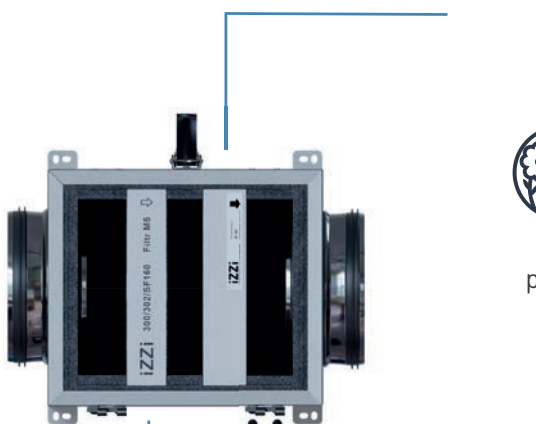

Pre-filtration

**F7**  
Spring  
Summer



Fine pollen



Mould and fungal spores



Bacteria and viruses

**F9**  
Fall  
Winter



Smog



Mould and fungal spores



Bacteria and viruses

**M5**  
Spring  
Summer  
Fall  
Winter



Dust



Pollen



Preliminary dirt  
(sand, insects,  
seeds and fine hair)



## Anti-smog filter boxes with PTC pre-heater

The **izzi SF 200 boxes** with a heater are an advanced solution that combines the benefits of a filter box and a preheater. They are equipped with a set of anti-smog or pollen filters that effectively purify the incoming air from harmful pollutants. Additionally, the preheater with a modern, smoothly controlled PTC heating element supports the anti-freeze system in izzi recuperators, ensuring optimal operating conditions for the ventilation system.

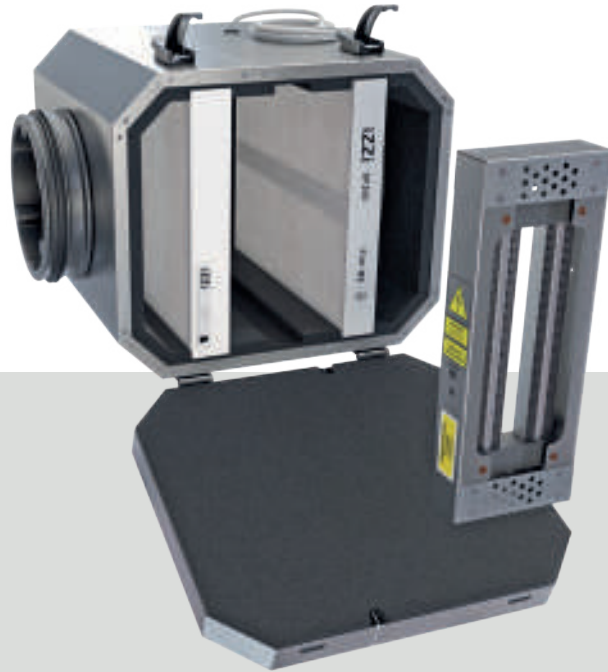

### Key features

#### Advantages of installing a pre-heater:

**Frost protection:** the pre-heater helps to maintain the right temperature in the heat exchanger in the recuperator, which prevents it from freezing, even when the temperature outside is very low.

**Energy saving:** by preventing freezing and increasing heat recovery efficiency, the pre-heater saves energy.

**No negative pressure:** activating the preheater replaces the operation of the vacuum-based anti-freeze system, which can cause cold air to be drawn in through leaks in the building.

**System reliability:** the pre-heater protects the operation of the recuperator in adverse conditions of low temperature and high humidity, increasing its durability and reliability.

**Improved air quality:** the pre-heater prevents the filters from freezing and increases their efficiency, allowing the supply air to be cleaned more effectively.

**Dedicated  
for recuperators**



**izzi H.302 ERV**



**izzi V.302/402 ERV**

## Stop the smog

Smog is polluted air that forms as a result of the mixture of smoke and fog, as well as harmful substances contained in emissions from vehicles, industry, and coal combustion. Smog is dangerous to health because it contains toxic substances

such as nitrogen oxides and sulphur dioxide, which can cause asthma, respiratory and cardiovascular diseases. In some cities, smog is a particularly serious problem, but it can occur wherever air pollution levels are high.

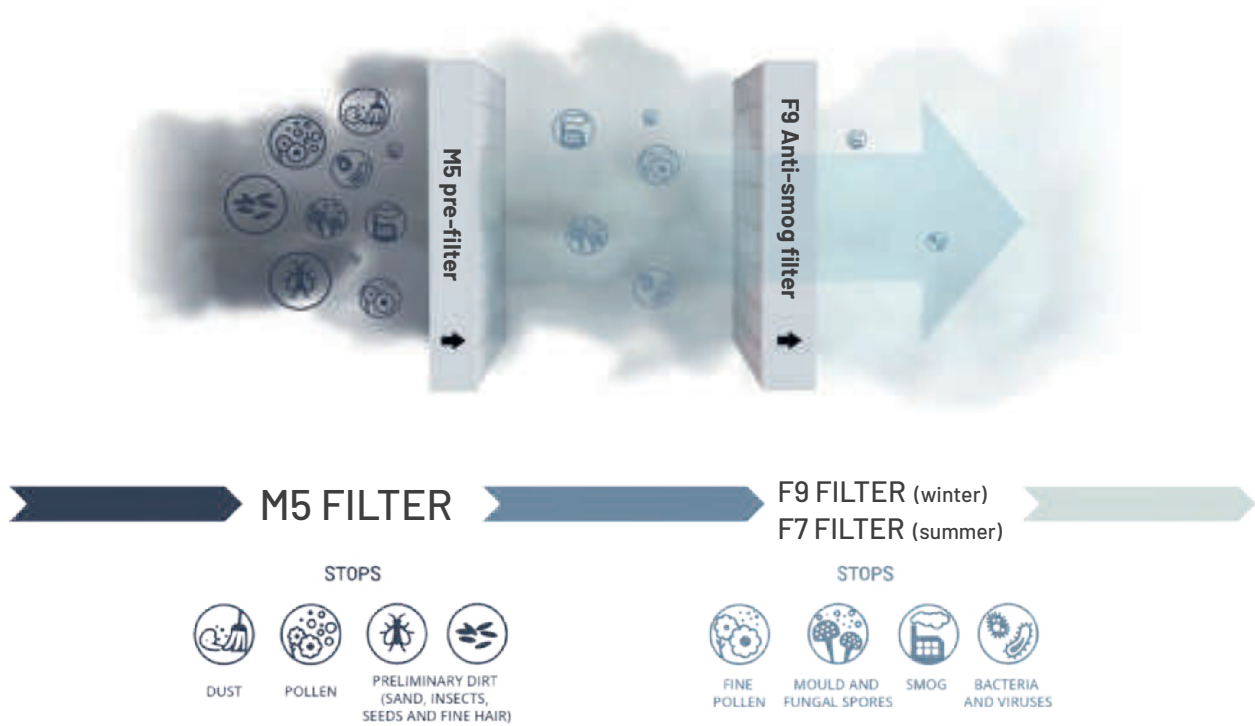

The two-stage filtration process of the izzi SF 200 filter box ensures the effective retention of more than 80% of the finest smog particles of the PM1 fraction, which are particularly harmful to our body as they can penetrate directly into the bloodstream through the lungs, spreading through our body to various internal organs. The filtration

process is based on the use of two pleated filters, including an accurate F9 rated anti-smog filter, which is responsible for trapping fine PM1 particles. Unfortunately, most anti-smog filters available on the market only provide protection against larger particles, such as PM10 and PM2.5, which, in practice, is insufficient protection.

### Filtration efficiency for particulate pollutants of different diameters

PM10 (10 µm)	96%
PM2,5 (2,5 µm)	90%
PM1 (1 µm)	83%

## Comfort even down to -15°C

When it is colder, to protect the heat exchanger, the recuperator's automation cyclically activates the vacuum anti-freezing system, which involves temporarily reducing the speed of the supply fan. All additional operating modes are also locked during this time. The recuperator automatics switches on the vacuum anti-freeze system, which consists of

temporary decrease of the supply fan speed. All additional operating modes, such as ventilation mode and the possibility of changing the fans' capacity, are also blocked for this time.

## Possible use of filter boxes during the year:

Highly accurate filtration

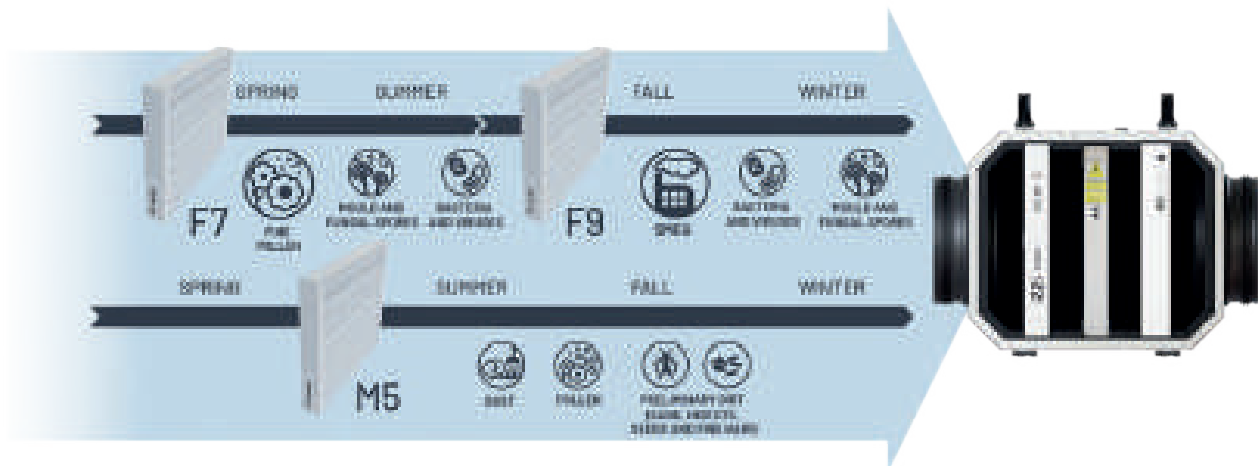

Coarse filtration



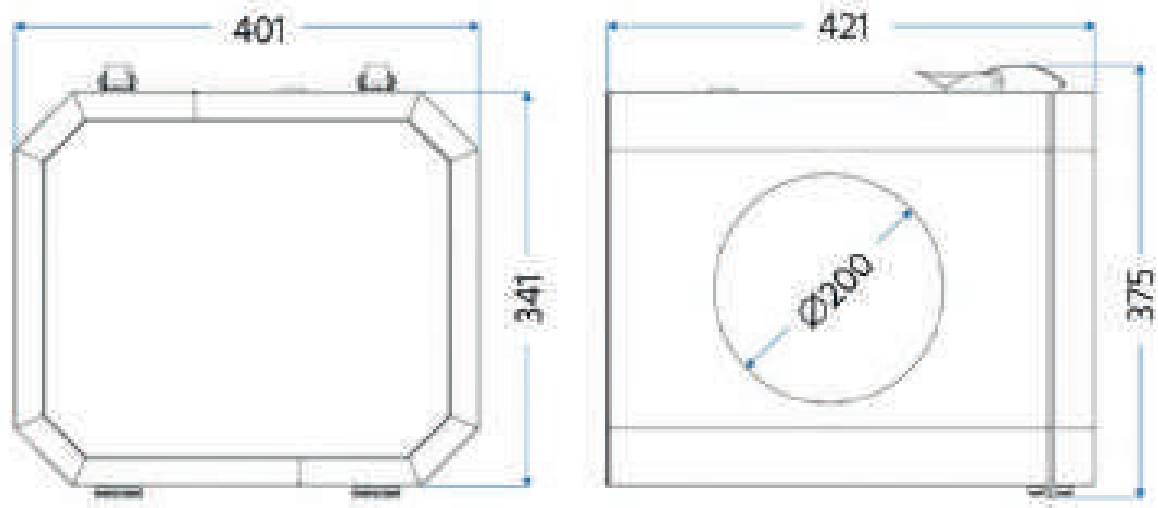

Box model	Anti-smog filter box with PTC pre-heater
Supply voltage	230V AC 50Hz
Rating power	500 W
Protection level	IPX3
Preliminary filter class	M5 / ePM10 75%
Preliminary filter surface	1,1 m <sup>2</sup>
Filter class (anti-smog)	F9* / ePM1 80%**
Filter class (anti-pollen)	F7* / ePM1 55%**
Fine filter surface	1,7 m <sup>2</sup>
Maximum air flow	up to 550 m <sup>3</sup> /h
Casing material	stainless steel 46 dB(A)
Internal insulation	closed-cell foam PE 30 mm
Spigot diameter	Ø200 mm
Filter dimensions	350x300x40 mm

**CENNIK24.pl** is a sales platform that connects manufacturers of installation systems, including mechanical ventilation and recuperators. The portal offers a complete range of mechanical ventilation components from PEFLEX and recuperators from the REQNET brand.

### *Advantages:*

- ▶ buying directly from manufacturers
- ▶ best conditions of cooperation
- ▶ all products in one place
- ▶ fast delivery times
- ▶ customization of individual distribution boxes is possible through the BOXMAKER software
- ▶ direct contact and support from manufacturers
- ▶ stability of catalog prices

# CENNIK



# Do you need a ventilation design?

## *Trust the specialists!*

A custom-designed mechanical ventilation system with heat recovery for a single-family house ensures the proper layout of the installation and maximizes its potential.



*The mechanical ventilation design with heat recovery includes:*

- Installation design
- Description and installation guidelines
- Material list and cost estimation





Scan the code to learn more!





# Do you install mechanical ventilation systems?

## Check out what we have for you:

-  The best possible commercial terms
-  A complete list of materials needed for the installation, along with pricing
-  Minimal purchasing procedure
-  Support from experienced professionals

*Contact us and join our network of installers!*

Get in touch with our sales team

+48 570 269 446



## **PEFLEX**

ul. Nowa Wieś 103  
32-420 Gdów

## **REQNET**

ul. Nowa Wieś 105  
32-420 Gdów



[www.peflex.eu](http://www.peflex.eu)  
[www.reqnet.eu](http://www.reqnet.eu)  
[www.cennik24.pl](http://www.cennik24.pl)

The manufacturer reserves the right to make changes to the colors, dimensions, and features of the presented products. This catalog is published for informational purposes only. The catalog presents sample patterns from the offer. Copying and distributing any materials from the catalog without the written consent of the publisher is prohibited. Colors in the catalog may differ from reality. All data contained in the catalog is valid in the month the catalog was printed - February 2025.